



**REPUBLIC OF BULGARIA**  
**NATIONAL AIR, MARITIME AND RAILWAY TRANSPORT, ACCIDENTS**  
**INVESTIGATION BOARD (NAMRTAIB)**

9 Dyakon Ignatiy str., Sofia 1000  
tel. (+359 2) 940 9317  
fax: (+3592) 940 9350

[bskrobanski@mtc.government.bg](mailto:bskrobanski@mtc.government.bg)  
[bskrobanski@abv.bg](mailto:bskrobanski@abv.bg)

**FINAL REPORT**  
**from**

**investigation of railway accident – fire in fast train № 2613 during motion between the stations  
Kaspitchan and Provadiya on 03.11.2022**



## **OBJECTIVE OF INVESTIGATION AND EXTENT OF RESPONSIBILITY**

The National Air, Maritime and Railway Transport Accidents Investigation Board (NAMRTAIB), which is an independent body performs the investigation of significant accidents, accidents and incidents. The National Board is within the Council of Ministers (CM) of the Republic of Bulgaria, and aims to find the circumstances and causes that led to the accidents and incidents occurrence in order to improve the safety and to avoid such in future.

**The investigation, which the NAMRTAIB performed is independent from any judicial investigation, and does not include the determination of fault or responsibility.**

The investigation is performed in accordance with the requirements of DIRECTIVE (EU) 2016/798 of the European Parliament and of the Council of 11 May 2016 on railway transport safety, the Railway Transport Act (RTA), Ordinance No59 dated 5.12.2006 on the rail transport safety management, as well as per Agreement dated 11.04.2023 on the interaction during investigation of accidents and incidents in the air, maritime and railway transport between the Prosecutor's Office of the Republic of Bulgaria, Ministry of Interior, and the National Air, Maritime and Railway Transport Accidents Investigation Board.

The Investigation reports follow the requirements of REGULATION (EU) 2020/572 of the Commission dated 24 April 2020 on the reporting structure for railway accident and incident investigation reports.

## TABLE OF CONTENTS

No	Title of section	Pg.
1.	<a href="#"><u>Summary</u></a>	5
2.	<a href="#"><u>Investigation</u></a>	9
3.	<a href="#"><u>Description of the event</u></a>	13
4.	<a href="#"><u>Analysis of the event</u></a>	24
5.	<a href="#"><u>Conclusions</u></a>	50
6.	<a href="#"><u>Safety recommendations</u></a>	52

## ABBREVIATIONS, USED IN THE REPORT

ABS – Automatic Block System  
FT – Fast train  
BDZ PS EOOD – „BDZ-Passenger Services“ EOOD – state railway undertaking for passengers  
VTU – Higher school of transportation “Todor Kableshkov” – Sofia  
DG FSaCP – Directorate General Fire Safety and Civil Protection  
SE NRIC – State enterprise „National railway Infrastructure Company “(railway infrastructure manager)  
RS – Railway section  
RTA – Railway Transport Act  
TOU – Traffic organization unit  
km – Kilometre along the rail track  
OCL – Overhead contact line (catenary)  
ECM – Entity in Charge of Maintenance  
Ordinance № 59/05.12.2006 – Ordinance on the rail transport safety management  
Ordinance № 13/30.12.2005 – Ordinance for ensuring health and safety labor conditions in the rail transport  
NAMRTAIB – National Air, Maritime, and Railway Transport Accidents Investigation Board (Independent Specialized National Investigation Body)  
RAEA/NSA – Railway Administration Executive Agency, National Safety Authority  
TF – Task Force (nominated by the railway infrastructure manager within each occurred accident or incident of the railway infrastructure)  
SE – Signalling equipment  
SABS – Semi-automatic Block System  
RRS – Rail Rolling Stock  
RD FSaCP – Regional department Fire Safety and Civil Protection  
TOMR – Train operation management and reporting  
RD MoI – Regional department within the Ministry of Interior  
REDU – Regional Electrical Distribution Unit  
SMS – Safety Management System  
DIB – Distant information board  
TOSAMD – Train operation and station activity management Division  
DCCM – Device for communications, connections and messages  
PTC – Professional Training Centre at BDZ  
CRP- Centre for retraining of personnel at SE NRIC  
TDRC – Train-dispatching radio connection

## 1. Summary

### 1.1. Brief Description of the Event.

On November 3, 2022, at 13:15 p.m., FT No. 2613, consisting of 4 passenger coaches, 16 axles, 159 tons (fig. 1.1) with locomotive No. 91521080041-2 (fig. 1.2) with a locomotive driver, assistant locomotive driver and a transport crew with a train master and conductor, departed from Sofia station. The train ran daily according to the train schedule in the direction of Sofia - Gorna Oryahovitsa - Varna. The railway company „BDZ-Passenger Services“ EOOD, national carrier of the Republic of Bulgaria,



**Fig. 1.1.**



**Fig. 1.2.**

operated the train and the rolling stock is its property.

The train arrived under schedule at Kaspitchan station, at 19:28 p.m. and, after a 4-minute delay, it departed at 19:32 p.m. Two kilometres after the Kaspitchan station in the direction of the Provadiya station on track No. 1, the locomotive driver noticed that the pressure in the Main air duct (MAD) dropped to 0 bar and the train stopped. A passenger traveling in the second coach, who smelled smoke and subsequently saw fire in the coach stopped the train with the emergency brake. After the emergency stop of the train at 19:35 p.m., the driver sent the assistant locomotive driver to check the connections between the locomotive and the first coach, and contacted the train master on the mobile phone. At the same moment, the assistant locomotive driver informed the locomotive driver that the train was on fire between the first and second coaches. The locomotive driver saw the fire and both immediately took measures to uncouple the train between the first and second coaches in order to prevent the fire from reaching the first coach. After the uncoupling, the locomotive driver attempted to drive away but found that the voltage in the catenary was switched off, and the two attempted to uncouple between the locomotive and the first coach and, with the help of passengers from the train, pushed the locomotive to a safe distance from the burning train. At the same time, the train master notified the national emergency number 112 about the fire. After receiving a notification at 19:41 p.m. about the fire that occurred, the train dispatcher of the Shumen - Varna section immediately ordered the energy dispatcher to turn off the voltage in the catenary on tracks No. 1 and No. 2 along the Kaspichan - Provadiya interstation. At 19:43 p.m., the voltage along the interstation was switched off.

The transport crew that serviced the train (train master and conductor) provided assistance to the passengers in removing them with their personal luggage from the train. No passengers or staff were injured in the fire. Damage was caused to the catenary (overhead contact network, to the first two burned passenger coaches of FT No. 2613: No. 50522974242-2 B4 (fig. 1.3, 1.4, 1.5) and No. 50521974003-0 A4 (fig. 1.6, 1.7, 1.8). The fire did not affect the third and fourth coaches of the train.





**Fig. 1.3.**



**Fig. 1.4.**



**Fig. 1.5. Condition of the internal part of passenger coach № 50522974242-2 after the fire.**



**Fig. 1.6.**



**Fig. 1.7.**



**Fig. 1.8. Condition of the internal part of coach № 50521974003-0.**



From the location of the fire to the Kaspitchan station, RD FSaCP cars took the passengers and the transport crew. Buses drove the passengers from Kaspitchan station to Varna station.

The authorities of RD FSaCP extinguished the fire in the coaches at 00:30 a.m. By order of the authorities from the pre-trial proceedings, the burnt train with the locomotive was left in place under the supervision and guard of the Ministry of Interior and the traffic along Kaspitchan - Provadiya interstation on track No. 1 remained interrupted from 21:47 p.m. on 03.11. 2022 until 16:14 p.m. on 04.11.2022.

At 00:57 a.m., the voltage was supplied to the catenary for restoring the traffic on track No. 2. The train movement between Kaspitchan and Provadiya stations was carried out bi-directionally on track No. 2 from 00:57 a.m. to 16:14 p.m. on 04.11.2022 ., when the train movement on track No. 1 was restored.

### 1.2. Location and time of the event occurrence.

Along Kaspitchan - Provadiya interstation on track No. 1 at km 462+000 at 19:35 p.m. during the movement of FT No. 2613, a fire broke out in the second coach (first class) and subsequently spread to the first coach (second class) next to the locomotive, as well as on the two coaches, the equipment in the salons burned completely (fig. 1.9).



**Fig. 1.9.-Scheme of burning of the coaches of FT 2613 along Kaspitchan-Provadiya interstation**

### 1.3. Factors determining and contributing the event.

A determining factor for the accident occurrence was the unsatisfactory technical condition of the power module of the lighting fixtures (inverter), installed in the fixtures in the corridor next to the coach exit. The inverter has a design defect between the circuit board and the power wires.

Contributing factors for the accident occurrence were both the performance of poor-quality repairs to the inverter powering the fluorescent lighting fixtures and the old design of the interior of the coach, which did not meet modern fire protection requirements for electrical installations and interior equipment, in accordance with Regulation (EU) No 1302/2014 of the Commission of November 18, 2014.

### 1.4. Direct causes and consequences of the event.

The accident occurred because of ignition of the power inverter of the fluorescent lighting unit in the corridor to the exit, in front of the toilet unit in the front part of the coach in the direction of train movement. The causes for that were complex:

- The strong burning of the hole for attaching the board to the housing of the power supply unit, which is a sign of the flow of large currents and heating to high temperatures.
- Condenser C1 has apparently punctured and its electrolyte has leaked, and its aluminium case has moved out of the insulating body, most likely due to improper technical specifications.
- During the inspection, it was found that when replacing individual elements of the power board, the soldering was not performed in the holes of the board (which is the correct way of soldering), but to the terminals of the removed damaged elements.
- During the installation of the lighting unit, the bundle of wires was not flanged (bandaged), but was also painted with white paint, which on the one hand worsened their normal heat exchange, and on the other led to a deterioration of their insulating qualities due to the aggressive components contained in the paint.

The consequences from the event are two coaches completely burnt (first and second class) from the composition of FT № 2613 and burnt personal belongings and luggage of the passengers, travelled in the first class coach.

### **1.5. Safety recommendations and addressees to which they are addressed.**

In order to prevent other similar accidents, the Investigation Commission proposes to the National Safety Authority RAEA safety recommendations related to the railway undertaking “BDZ-Passenger Services” EOOD and SE NRIC.

- Recommendation 1, proposes that SE NRIC and "BDZ-Passenger Services" EOOD familiarize the interested personnel with the contents of the report.
- Recommendation 2, proposes that BDZ PS EOOD organizes the performance of monthly discussions and gets acquainted the operation and repair personnel in the wagon-repair depots of the entity with the circumstances and causes for the accident occurrence.
- Recommendation 3, proposes BDZ PS EOOD, when carrying out major repairs of passenger coaches in railway depot, to control the requirements for compliance with the relevant fire protection requirements for electrical installations and internal equipment, listed in Regulation (EU) No. 1302/2014 of the Commission of November 18, 2014.
- Recommendation 4 proposes BDZ PS EOOD during the monthly electrical revisions of the passenger coaches, series 1974 and 2974 to undertake inspection and measurements of the electrical installations and equipment in order to prevent ignition of other coaches. To install video surveillance cameras in the passenger coaches.
- Recommendation 5, proposes that the Railway Administration Executive Agency undertakes an amendment and supplement to the legislation regulating the actions of the operating personnel related to switching off and switching on the voltage in the catenary in emergency cases where a fire has occurred in the rolling stock (locomotive or wagons) during the train movement along interstation.



## **2. Investigation**

### ***2.1. Decision for starting the investigation.***

On November 3, 2023, at 19:35 p.m., the member of Management Board of the NAMRTAIB in the Republic of Bulgaria, with the competence to investigate railway accidents was notified by mobile phone by the dispatcher on duty of BDZ PS EOOD about a fire that had occurred in the coaches of FT No. 2613. At 19:40 p.m. followed a written notification by SMS from the dispatcher on duty with the railway infrastructure manager SE NRIC on the same accident at the Kaspitchan - Provadiya interstation.

Given the severity of the accident and its impact on railway transport safety, the member of the Management Board of the NAMRTAIB in the Republic of Bulgaria, leading the investigation of railway accidents and incidents, took a decision to start the safety investigation in accordance with the requirements of art. 22, paragraph 3 of Directive (EU) 2016/798 of EPC and art. 71, par. 1, par. 2 and par. 3 of Ordinance № 59.

The investigation aims to improve the safety in the rail transport and to prevent, and avoid other accidents emphasizing the prevention of serious accidents.

### ***2.2. Motives for the decision to initiate the investigation.***

The member of the Management Board of the NAMRTAIB, took the decision to initiate the investigation based on art. 20, paragraph 2 (a) of Directive (EU) 2016/798, art. 115к, paragraph 1, item 2 of RTA, and art. 76, par. 1, item 2 of Ordinance No 59 dated 5.12.2006.

The investigation was undertaken considering the circumstances that led to the occurrence and rapid growth of the fire in the passenger coaches (first and second class) of FT No. 2613, during the train movement, which led to the complete burning of the two coaches of the train.

### ***2.3. Scope and restrictions of the investigation.***

The procedure of the investigation analysed the organizational and human factor, the Safety Management System related to the repair and maintenance, including the risk assessment with registered hazards of the traction rolling stock (passenger coaches) and the entity in charge of maintenance of the rolling stock in the railway undertaking "BDZ-Passenger Services" EOOD and the normative acts to it.

During the investigation of the accident, restrictions and delays were not allowed.

### ***2.4. Competences of the persons, involved in the investigation.***

In accordance with the requirements of art. 22, paragraph 1 of Directive 2016/798 the member of the Management Board of the NAMRTAIB, head of the railway transport unit headed the Investigation Commission. The members of the Commission are independent external experts - qualified persons from higher transport educational institutions, scientific circles, experts with qualifications in the field of railway infrastructure, rail rolling stock, and management and operation of train traffic. These experts participate in the Investigation Commission with individual civil contracts.

### ***2.5. Communication and consultations with the persons and entities, involved in the event.***

In accordance with Ordinance No. 59 on Railway Safety Management, the Head of the Investigation Commission notified the individuals and entities that he was opening an investigation into the safety accident. The Safety Investigation Commission determined the parameters of the investigation and coordinated its actions with the Task Force, which includes representatives of both entities (BDZ PS EOOD and SE NRIC). According to the regulations, the Task Force collected documents, samples, written statements of the personnel of the two entities, the records from the recording devices of the locomotive serving FT No. 2613 and records of official telephone conversations. The materials and documents were handed over to the Head of the investigation at the NAMRTAIB. BDZ PS EOOD requested and provided information about the personnel who serviced FT No. 2613 and the regulations for the repair and maintenance of passenger coaches, listed in the SMS. An interview was conducted with the safety authorities of the two entities and with the managers of the railway enterprises BDZ PS EOOD and SE NRIC.

## ***2.6. Degree of cooperation from the participating entities.***

During the investigation by the Commission at the NAMRATIB, the managers of the railway undertaking BDZ PS EOOD and the representatives of SE NRIC provided full assistance and a complete set of all the necessary materials and documents. Full access to the composition of FT No. 2613 (the burnt wagons in the Wagon-Repair Depot Gorna Oryahovitsa) was provided for carrying out inspections, measurements and expertise.

## ***2.7. Methods and techniques of investigation and analysis.***

On 03.11.2022, the bodies of RS FSaCP Kaspitchan and Shumen were the first to arrive at the place of the accident and began extinguishing the two burning coaches. After the fire was extinguished in the coaches, the pre-trial proceedings authorities from the RD MoI Shumen were the first to carry out inspections under the regulations of the supervising prosecutor from the Shumen RP.

On 04.11.2022, the Head of the Safety Investigation at the NAMRATIB went to the place of the accident, where the following took place and he found:

- Inspections of the burned coaches were carried out together with the authorities of the pre-trial proceedings from the RD Shumen of the Ministry of Interior and RS FSaCP Kaspitchan, as well as the remaining two coaches (not burnt) of the train and locomotive No 91521080041-2, servicing FT No2613;

- The fire in FT No. 2613 started in the second coach No. 50521974003-0 (first class) in the area of the exit corridor and the toilet, after the fire spread it also covered the first coach No. 50522974242-2 (second class), next to the locomotive;

- With the efforts of the locomotive crew and passengers from the train, the locomotive was detached from the train and moved by hand to a safe distance from the burning coaches. The access to the train was restricted to outsiders and the train was guarded by the authorities of the Ministry of Interior Kaspitchan at the stopping place at the Kaspitchan - Provadiya Track No. 1 interchange at km 462+000 (the buffers between the first and second coach);

- A protocol of the performed inspections has been drawn up. The authorities of the pre-trial proceedings from the Ministry of Interior Shumen and RS FSaCP Kaspitchan seized parts and burnt remnants of cables from the electrical installations of the coach in which the fire occurred, for research and preparation of expertise in the laboratory of DG FSaCP Sofia in order to establish the causes;

- After completion of the procedural-investigative actions and completion of the safety inspections, permission was given to the head of the Task Force to organize the withdrawal of the train from the interstation to the Kaspitchan station;

- A written permission was given by the authorities of the pre-trial proceedings and the Head of the Safety Investigation at the NAMRATIB, to take the train to the Wagon-Repair Depot Gorna Oryahovitsa, where to start a safety investigation and an investigation by the authorities of the pre-trial proceedings in order to establish the causes for occurrence of the fire in the coach;

- On 04.11.2022, the coach composition of FT No. 2613 was moved from the Kaspitchan station to the Gorna Oryahovitsa wagon repair depot and placed under supervision without the right of access under the regulations of the supervising prosecutor from RPO Shumen.

- On 04.11.2022 at 16:14 p.m. after inspections and permission given by experts of SE NRIC, voltage was applied to the catenary between Kaspitchan and Provadiya stations on track No. 1, the movement of trains was restored at scheduled speed.

- On 11.01.2023, by written order of the supervising prosecutor from RPO Shumen FT No. 2613 was released from supervision, located in the Wagon-Repair Depot Gorna Oryahovitsa.

On 11.01.2023, the Safety Investigation Commission at the NAMRATIB was allowed to launch an investigation of the accident at the Gorna Oryahovitsa Wagon Repair Depot in order to establish the circumstances and causes that led to the fire of the coach, where:

- An interview was conducted with the locomotive and transport crews of FT No. 2613, who directed the Commission to investigate the possible occurrence of the fire in the first toilet of the second coach;

- The testimony of the passengers traveling in the second compartment of the second coach of the train confirmed that the fumigation started from the area of the corridor in front or in the toilet of the coach;

- Comprehensive inspections were carried out of the burned second coach No. 50521974003-0, which is first-class, and of the first coach No. 50522974242-2, which is second-class;

- Remains of cables and other elements of the electrical equipment of the coach were dismantled in the area of the entrance corridor to the toilet;

- The fire completely destroyed all the equipment and furnishings of the two coaches from the frame to the roof structure;

- Only the rigid metal seat structures were available;

- Many burnt personal belongings of passengers traveling in the first coaches were found.

The safety Investigation Commission demanded from the railway enterprise BDZ PS EOOD - the owner of the coaches, all the documentation for the two coaches, presenting the operation and the repairs carried out up to the time of the fire.

On 17.11.2022, the chairman of the Commission for Safety Investigation at the NAMRATIB received from the head of the Task Force TOSAMD - Gorna Oryahovitsa the collected materials and documents (including photographic material) regarding the railway accident - a fire that occurred in the second coach of FT No. 2613 during movement along the Kaspitchan - Provadiya interstation on 03.11.2022.

In the period 22.03.-24.03.2023, the Commission for Safety Investigation carried out additional inspections and measurements of the burned-out second coach at the Gorna Oryahovitsa wagon repair depot together with experts from the wagon depot and employees of BDZ PS EOOD.

### ***2.8. Difficulties faced during the investigation.***

During the investigation, the Investigation Commission of the NAMRATIB did not encounter any difficulties. The representatives of the Task Force and the safety authorities of the Railway Infrastructure Manager and the Railway Undertaking provided full cooperation to the safety Investigation Commission.

### ***2.9. Interaction with the judicial authorities.***

On 04.11.2022, after the parallel inspections, the authorities of the pre-trial proceedings from RPO Shumen seized remains of cables and electrical equipment from the burned second coach for examination and preparation of expertise. Contacts were exchanged with the safety investigation manager for interaction and cooperation regarding the clarification of the circumstances and causes of the accident

In accordance with the effective from 11.04.2023 Agreement on interaction between the pre-trial proceedings authorities from the RD Shumen of the Ministry of Interior and the supervising prosecutor from the RPO Shumen and the Safety Investigation Commission at the NAMRATIB, in the process of the investigation an exchange of information, documents and materials was carried out. The authorities of the pre-trial proceedings from the RD Shumen at the Ministry of Interior and the supervising prosecutor from the RPO Shumen have appointed the preparation of a Complex fire and electrical expertise in order to establish the causes that led to the occurrence of the accident. It was prepared in the DG FSaCP on 20.02.2023.

### ***2.10. Interaction with the judicial authorities.***

In connection with the provisions of the Agreement on interaction between the Prosecutor's Office of the Republic of Bulgaria, the Ministry of Interior and the NAMRATIB, the head of the safety investigation from the NAMRATIB received from the authorities of the pre-trial proceedings a copy of the recorded written statements of passengers traveling in the second compartment of the second coach of FT No. 2613 on 03.11.2022 and a copy of the Complex Fire and Electrical Expertise prepared by the DG FSaCP at the Ministry of the Interior.

After providing the records taken by the "RED BOX" type recorder of electric locomotive No. 91521080041-2, servicing FT No. 2613 on 03.11.2022, it was found that the speed of the train before the

accident was 70 km/h and the stop of the train was caused by a passenger who activated the emergency brake in the third coach. The permissible speed for trains between Kaspitchan and Provadiya stations is 80 km/h. Decryption of the records was carried out by the railway company BDZ PS EOOD and was handed over to the head of the safety investigation in order to use the information for the needs of the investigation.



### **3. Description of the event**

#### **3.1. Information on the event and the context.**

##### *3.1.1. Description of the event type.*

On November 3, 2022, at 13:15 p.m., FT No. 2613 departed from Sofia station, consisting of 4 coaches, 16 axles, 159 tons, serviced by locomotive No. 91521080041-2 with a locomotive driver and an assistant locomotive driver, and a transport crew, train manager and conductor. A total of 160 first and second class passengers travelled on the train from the origin station. The train run daily according to the train schedule in the direction of Sofia - Gorna Oryahovitsa - Varna. The train was operated by the railway company "BDZ-Passenger Services" EOOD, the national railway undertaking of the Republic of Bulgaria, and the rolling stock is its property. The staff on-duty at the stations along the route of the train did not notice any irregularities.

The train was accepted at Kaspitchan station at 19:28 p.m. on the first track. After a stay of 4 minutes, it departed at 19:32 p.m. with a delay of 2 minutes for disembarking and boarding of passengers. Since the departure of FT No. 2613 from Kaspitchan station, 17 passengers have travelled in the first-class coach (which was the second in order of the train) and 39 passengers in the three second-class coaches. When the train left the station and moved along Kaspitchan - Provadiya interstation on track No. 1, the locomotive driver noticed that the pressure in the main air duct (MAD) dropped to 0 bar and the train stopped at 19:35 p.m. After the stop, the locomotive driver sent the assistant locomotive driver to check the connections between the locomotive and the first coach, and he called the train master by mobile phone. At the same moment, the assistant locomotive driver informed him that between the first and the second coach the train was on fire. They immediately took measures to uncouple the train between the first and second burning coaches in order to prevent the fire from spreading to the first coach. After uncoupling, the driver tried to depart, but found that the voltage in the catenary was switched off and, together with the assistant, undertook the uncoupling between the locomotive and the first coach, after which, with the help of passengers who have disembarked from the train, they pushed the locomotive to a safe distance. At the same time, the train master called the national emergency number 112 about the fire on the train.

The train dispatcher, managing the train operation along Shumen - Varna section, was notified at 19:40 p.m. about the situation by the senior train dispatcher, who at 19:37 p.m. received the information from the national emergency telephone number 112 to direct the specialized vehicles of RS FSaCP from Novi Pazar to the place of the fire. The senior train dispatcher and the train dispatcher, before establishing a telephone connection with the locomotive driver about the situation on the spot, ordered the energy dispatcher to turn off the voltage in the catenary on track No. 1 and No. 2 along the Kaspitchan-Provadiya interstation. At 19:43 p.m., the energy dispatcher confirmed that the voltage in the catenary along the interstation on track No. 1 and No. 2 was switched off.

At the same time, DFT No. 90596 of the railway undertaking "Bulmarket Rail Cargo" OOD was moving on current track No. 2, which, also due to the disconnection of the voltage, stopped along the interstation.

At 21:45 p.m., the train dispatcher contacted the locomotive drivers of FT No. 2613 and DFT No. 90596 by mobile phone and specified their locations. At 21:47 p.m., the train operation on track No. 1 along the Kaspitchan - Provadiya interstation was interrupted.

To extinguish the fire in the first two coaches of FT No. 2613, two specialized vehicles of RS FSaCP Novi Pazar and subsequently another three vehicles of RS FSaCP Shumen arrived on the spot.

The passengers from the train, together with the transport crew, were taken by RS FSaCP cars to the Kaspitchan station. From Kaspitchan station at 22:30 p.m., passengers were taken by buses to Varna station.

At 00:30 a.m. RS FSaCP put out the fire in both coaches. The third and fourth coaches of FT No. 2613 were not affected by the fire.

At 00:57 a.m. at the Kaspitchan - Provadiya interstation on road No. 2, voltage was applied to the contact network.

At 00:57 a.m., the traffic on track No. 2 between Kaspitchan and Provadiya stations was restored bi-directionally, and the accident site was passed at a speed of up to 15 km/h.

The movement of trains on track No. 1 has been interrupted and the voltage in the catenary has been switched off. The composition of FT No. 2613 and the locomotive remained under the supervision and protection of the authorities of the Ministry of Interior by order of the pre-trial proceedings authorities.








On 04.11.2022, the head of the safety investigation at the NAMRATIB and the pre-trial proceedings authorities from the Directorate of the Ministry of Interior Shumen, after conducting parallel inspections of the burned coaches, as well as the other two coaches of the train and the locomotive No. 91521080041-2, serviced FT No. 2613, they allowed the withdrawal of the train from the interstation at Kaspitchan station and the restoration of the train traffic on track No. 1.

### 3.1.2. Date, punctual time and location of the event.

On November 3, 2022, at 19:35 p.m., the fire broke out in the second coach of the first class train in the corridor in front of the toilet unit at the exit. The train stopped at km 462+000 along the Kaspitchan - Provadiya interstation on track No. 1, after the emergency brake was activated by a passenger on the train. The rail track is in a straight section with an inclination of 0.5 ‰ downhill (Fig. 3.1).



**Fig. 3.1. The passed route of FT № 2613 with the place of the accident.**

-  - Origin station of FT № 2613;
-  - Main stations along the train alignment;
-  - Final destination station;
-  - Station, where the change of the locomotive and transport crew was performed;
-  - Place of the accident;
-  - Track, which FT № 2613 has passed;
-  - Track, which FT № 2613 was about to pass;

FT № 2613 run along the main line № 2 in Sofia – Gorna Oryahovitsa – Varna direction (fig. 3.2).



**Fig. 3.2. Map of the movement route of FT № 2613.**

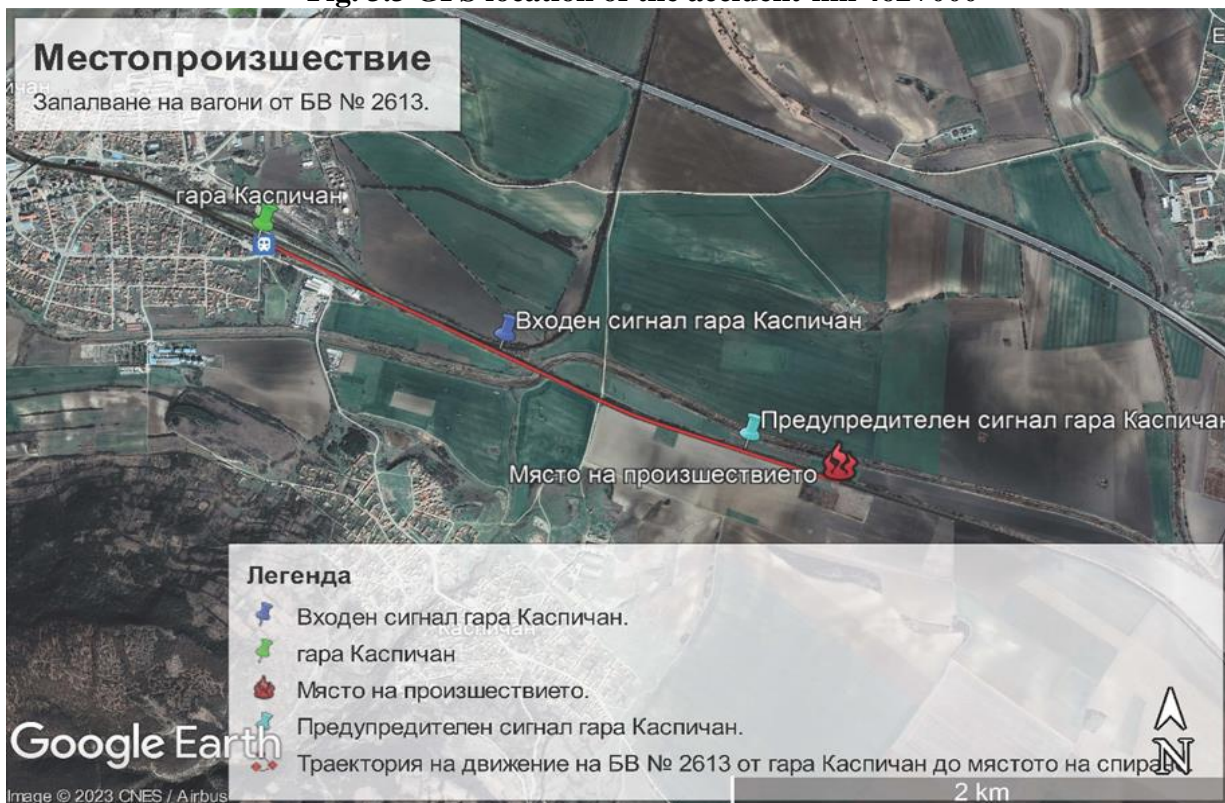
3.1.3. Description of the event location:

3.1.3.1. Location of the place of the accident (fig. 3.3).

Geographic width: 43°39'50.35"N

Geographic length: 22°43'58.14"E

**Fig. 3.3 GPS location of the accident-km 462+000**



**Фиг. 3.3. GPS локация на произшествието – км 462+000.**



*3.1.3.2. Meteorological and geographical condition at the time of the event on 06.01.2023 г.*

- In the dark part of the day – 19:35 p.m.;
- Average air temperature: 12°C;
- Average wind speed and direction 0 m/s;
- Weather – clear with insignificant cloudiness;
- There is no registered reduced visibility and rains in the region.

*3.1.3.3. Performance of construction activities on the site or in vicinity.*

In the region between the stations Kaspitchan and Provadiya along track № 1 and track № 2 the railway infrastructure manager has not performed any construction works along the railway infrastructure (rail track and structures, catenary and signalling equipment) before the accident.

*3.1.4. Fatalities, injuries and material damages:*

*3.1.4.1. Employees of the railway infrastructure manager or railway undertaking.*

None.

*3.1.4.2. Other persons officially connected with the location of the event.*

None.

*3.1.4.3. Passengers.*

None.

*3.1.4.4. External persons.*

None.

*3.1.4.5. Cargo, luggage or other property.*

Personal belongings and luggage of the passengers traveling in the second coach No. 50521974003-0 A4 were burned due to heavy smoke and the rapid spread of the fire in the coach, this forced the passengers to leave quickly the coach without taking their personal luggage (fig. 3.4).



**Fig. 3.4.**



#### *3.1.4.6. Rolling stock, infrastructure and environment.*

- Material damage of the locomotive № 91521080041-2 – none;
- Material damages caused due to an ignition in two passenger coaches № 50522974242-2 series B4 and № 50521974003-0 series A4 amounting to 47 888,58 BGN;
- Damages caused to the track – none;
- Damages caused to the catenary – 2137,41 BGN.;
- Damages caused to the signalling and telecommunications – 7326,03 BGN;
- Damages to the environment – none;
- Total costs of the damages: **57 352,02 BGN.**

#### *3.1.5. Description of other consequences, including the event impact on the usual activity of the participants.*

In the period from 19:40 p.m. on 03/11/2022 to 16:15 p.m. on 04/11/2022, the manager of the railway infrastructure and the railway undertakings have generated additional costs for changing the train schedule and capacity along Shumen - Varna section.

- Deviated trains of the railway undertakings – 2, 11,09 BGN;
- Cancelled trains of the railway undertakings – none;
- Prepared schedules of the railway undertakings – 7, 952,69 BGN;
- Delayed trains of the railway undertakings – 16, 3245,90 BGN;
- Requested and unused capacity – none;
- Costs for rehabilitation means – none;
- Total other costs: **4 209,68 BGN.**

**TOTAL DAMAGES OF THE ACCIDENT – 61 561,70 BGN.**

#### *3.1.6. Identity of the participants and their functions.*

##### Railway infrastructure:

• SE National railway Infrastructure Company has a Safety Authorization which guarantees safe operation and maintenance of the railway infrastructure and the adjacent facilities. The company ensures equal and non-discriminatory access to all the licensed and certified railway undertakings for the transport of passengers and freights along the railway infrastructure of the Republic of Bulgaria.

SE NRIC personnel, involved in the accident:

- Traffic manager on-duty in TOSAMD Gorna Oryahovitsa station;
- Post switchman in Kaspitchan station;

##### Railway undertaking:

• BDZ PS EOOD holds a License and a Single Safety Certificate, which guarantees the provision of safe railway services for the transport of passengers on the railway network of the Republic of Bulgaria. BDZ PS EOOD is a national carrier.

Personnel of BDZ PS EOOD involved in the accident:

- Locomotive driver of locomotive № 91521080041-2 of FT № 2613;
- Assistant locomotive driver of locomotive № 91521080041-2 of FT № 2613;
- Train master of FT № 2613.

#### *3.1.7. Description of the respective parts of the railway infrastructure and signalling system:*

##### *3.1.7.1. Type of the track, railway switch, rail crossing etc..*

The Kaspitchan – Provadiya interstation is a double-track electrified conventional line, which is a part of the main railway line № 2.

##### *3.1.7.2. Interstation block system, station installation, type of signalling:*

The Kaspitchan – Provadiya interstation which is equipped with semi-automatic block system with SABS.

Kaspitchan station is equipped with RRI type WSSB, entrance and exit semaphores in the station are along the speed signalling – impersonal train traffic (the trains can run in both directions between the two stations with regular exit signals within the automatic block system) – functional;

Provadiya station – RRI type MH-70, entrance and exit semaphores are along the speed signalling – functional;

### 3.1.7.3. Train protection systems.

Kaspitchan station does not have a train protection system. The stations and interstation are equipped with train dispatch radio communication (TDCRC) and GSM R, with the help of which radio communication is carried out between the locomotive driver and the traffic manager on duty, with the train dispatcher, with individual stations and with the trains along the relevant railway section - serviceable.

Locomotive № 91521080041-2 is equipped with train dispatch radio communication (TDCRC) and GSM R, active type vigilance device and "RED BOX" type recording device - functional.

### 3.1.8. Other information referring the event.

#### 3.1.8.1. Train documents of „BDZ-Passenger services“ EOOD.

The train documents „Way-bill“, „Nature sheet“ „Accompanying sheet“, and „Brake mass certificate“ correspond to the hours of the actual movement of the train under the presented data of the TDCRC system and the locomotives encryption (fig. 3.5-3.10).

2613

СТУЖА С. Орzechовица		ПЪТЕН ЛИСТ № 161		ЛОКОМОТИВ № 80 041 2		СТУЖА СЛУЖБИ 1777		031122					
ЛОКОМОТИВНА БРИГАДА			ЯВЯВАНЕ			ОСВОБОЖДАВАНЕ			ПЪТУВАНЕ БЕЗ СЛУЖБА				
пункт №	име, презиме, фамилия	шифр	пункт	час, мин.	забележка	пункт	час, мин.	пункт	час, мин.	вид транспорт	до пункт	час, мин.	пункт
160	Орzechовица	01	ГО	1640	1777	ГО	0300	Станция	ГО	0300	Станция	1777	1777
1032	Славянославия	02	ГО	1640	1777	ГО	0300	Станция	ГО	0300	Станция	1777	1777
ПРИЕМАНЕ И ПРЕДАВАНЕ НА ЛОКОМОТИВА						ДОПЪЛНИТЕЛНО ПОЛУЧЕНО ГОРИВО ИЛИ МАСЛО							
пункт	лок. в токовата глава за експлоатация съгласно НТИ	показан на километража	налято гориво лок. електроенергия	час, мин.	сумма / гориво	лок. масл	пункт	вид	маса	количество	час, мин.	сумма	лок. масл
ГО	ГОСЕМ	405 065		1515	1515								
К	ГОСЕМ	405 235		0115	1630								
ИНСТРУКТОР / ИНСПЕКТОР			СТАРШИ КОНДУКТОР				СВЕРКА НА ЧАСОВНИЦИТЕ						
срочен	фамилия	от часа	до часа	подпис	вагон №	журн	1500 V	от часа	час, мин.	до часа	час, мин.	име, фамилия	подпис
					1515	журн	1500	1515	1515	1940	1940	1940	1940
ОБСЛУЖВАНЕ НА ВЛАСОВЕ И МАНЕВРЕНА РАБОТА						ДАНИИ ЗА СЪСТАВА НА ВЛАСОВЕТЕ							
№ на влак	гара км.	пункт км.	времетрае	времетрае	БЕТЕЖКОС - прен. за странични или нек. изведени по	лок. масл	брой ваг.	брой ося	брой ося	брой ося	брой ося	брой ося	брой ося
1613-8	ГО	КМ	1935	1935	1935	1935	19	119	4	16			

Fig. 3.5. Front part of a Way-bill

ОБСЛУЖВАНЕ НА ВЛAKOBE И МАНЕВРЕНА РАБОТА											ДАНИИ ЗА СЪСТАВА НА ВЛAKOBEТЕ																		
№ на влак		Гара код		ПРИБИТИЕ		ПРИКА		БЕЖЕЖИ - ПРИКЪЛЪЦИ ЗА СЪСТАВЪ НА ВЛ. СЪСТАВЪ					ЛОК. КОД	ДРУГИ ЛOK. №		МАСА НА СЪСТАВА		БРОЙ		БРОЙ ВЪС. ПЪЛН. ВЪГОНА				БРОЙ ОСА. ВЪГОНА		ФАКТИЧ.	ПОДМАС		
01		02		03		04		ЖЕЛ. ПЪЛН. КОМ. МОТОР. СЕПЪЛНИ. ОТКЪЛ. ПИЛИЧ. РЪКОВ. ВЪС. ПЪЛН. ДИЖОСТ - КОМБИКОМ. ТАР. ВЪГОН. И ДР.					05	06		07	08	09	10	11	12	13	14	15	16	17	18		

**ДРУГИ ВПИСВАНИЯ, ЗАБЕЛЕЖКИ** 0884 101 982

Доказателство за изисване на работни ресурси: *Док.*

Контролен лист

Не са върнети работни ресурси: *Къд. лок. К.Н. Док.*

<b>ПРЕДАВАНЕ НА ПЪТНИЯ ЛИСТ</b>	<b>КОНТРОЛ НА РЕГ. ПАРАМЕТРИ</b>	<b>СТАТИСТИЧЕСКА ОТЧЕТНОСТ</b>	<b>ЕНЕРГИЙНА ОТЧЕТНОСТ</b>																																																									
<table border="1" style="width:100%; border-collapse: collapse;"> <tr><th>присл.</th><th>бр. контрол.</th><th>дата</th><th>час, мин.</th><th>подпис</th></tr> <tr><td>01</td><td>02</td><td>03</td><td>04</td><td>05</td></tr> <tr><td>07</td><td>08</td><td>09.11.2022</td><td></td><td></td></tr> </table>	присл.	бр. контрол.	дата	час, мин.	подпис	01	02	03	04	05	07	08	09.11.2022			<table border="1" style="width:100%; border-collapse: collapse;"> <tr><th>дата</th><th>констатирани нарушения</th><th>проверени фактите</th><th>подпис</th></tr> <tr><td>01</td><td>02</td><td>03</td><td>04</td></tr> <tr><td></td><td></td><td></td><td></td></tr> </table>	дата	констатирани нарушения	проверени фактите	подпис	01	02	03	04					<table border="1" style="width:100%; border-collapse: collapse;"> <tr><th>дата</th><th>констатирани нарушения</th><th>проверени фактите</th><th>подпис</th></tr> <tr><td>01</td><td>02</td><td>03</td><td>04</td></tr> <tr><td></td><td></td><td></td><td></td></tr> </table>	дата	констатирани нарушения	проверени фактите	подпис	01	02	03	04					<table border="1" style="width:100%; border-collapse: collapse;"> <tr><th>дата</th><th>час, мин.</th><th>отказаните вагони</th><th>наличие на енергия</th><th>контролни фактите</th><th>подпис</th></tr> <tr><td>01</td><td>02</td><td>03</td><td>04</td><td>05</td><td>06</td></tr> <tr><td></td><td></td><td></td><td></td><td></td><td></td></tr> </table>	дата	час, мин.	отказаните вагони	наличие на енергия	контролни фактите	подпис	01	02	03	04	05	06						
присл.	бр. контрол.	дата	час, мин.	подпис																																																								
01	02	03	04	05																																																								
07	08	09.11.2022																																																										
дата	констатирани нарушения	проверени фактите	подпис																																																									
01	02	03	04																																																									
дата	констатирани нарушения	проверени фактите	подпис																																																									
01	02	03	04																																																									
дата	час, мин.	отказаните вагони	наличие на енергия	контролни фактите	подпис																																																							
01	02	03	04	05	06																																																							

Ф 2103

Fig. 3.5. Rear part of a Way-bill

№С 80077  
 ГМ: 088430177

“БДЖ-ПП” ЕООД Формат ДП-1

**НАТУРЕН ЛИСТ НА ВЛAK № 5013**

Превозач: \_\_\_\_\_  
 Гара на съставяне на влак: *Сопот*  
 Дата и час на тръгване: *3.11.2022* Крайна гара: *Варна*  
Дата и час на пристигане: *R 13 45*

№ на вл.	Въгон номер	ВАГОН												Отпращаваща гара (по документ)	Получаваща гара (по документ)	Вид на товара	Получател	Вагони оставени в гара
		№	сери	роковици	данни	статус	№	Вид на съдърж.	Масов пр.	Височина	Тегло	Нето	Бруто					
1	19242422	В	50	52	4	11	56	3,5	5	70	21	611	Варна	п.г.				
2	19242020	В				4	56	3,5	4	39								
3	19241023	В				4	56	3,5	5	70								
4	19242414	В				4	56	3,5	5	70								
		4	16		840		19		= 1592									
																		НСП

*Варна*

Fig. 3.6. Nature sheet of the train

**ПРИДРОЖИТЕЛЕН ЛИСТ НА ВАГА № 2613**  
Обр. В.21

Президент: *Селян - nn - 8002* / СЕЛАН ПЕТРОВ  
Началник: *Сидев* / СИДЕВ  
Дата: *03.11.2022*  
Час на пристигане: *13<sup>15</sup>*

Краен пункт: *Варна*  
Дата: *03.11*  
Час на пристигане: *20<sup>15</sup>*

Тип и серия	Пристига				Тръгна				Промет в токове и приливи	Състав и тежест на вагона				
	У	В	П	И	У	В	П	И		Килограма	Тона	Тона	Тона	Тона
<i>Спиралка</i>	-	-	-	-	13	15	16	18	-	1.2	1.2	1.2	1.2	1.2
<i>Спиралка</i>	14	10	1	12	14	10	1	12	-	1.2	1.2	1.2	1.2	
<i>Спиралка</i>	15	09	1	12	15	09	1	12	-	1.2	1.2	1.2	1.2	
<i>Спиралка</i>	16	14	1	12	16	14	1	12	-	1.2	1.2	1.2	1.2	
<i>Спиралка</i>	17	04	1	12	17	04	1	12	-	1.2	1.2	1.2	1.2	
<i>Спиралка</i>	18	18	1	12	18	18	1	12	-	1.2	1.2	1.2	1.2	
<i>Спиралка</i>	19	15	1	12	19	15	1	12	-	1.2	1.2	1.2	1.2	
<i>Спиралка</i>	20	15	1	12	20	15	1	12	-	1.2	1.2	1.2	1.2	

1. Основа на спиралката на *спиралка*/вотерни вагон изпитана и скоростен регистър  
2. Последно подаване на напрежение *ДА*  *НЕ*   
3. Часовният скорост  
Дата *03.11.2022* Тип *С. Спиралка* Дик. р-т *С* Не вагон  Маса *1.2*  
Час *13* Мин. *15* Вагон *13* Дик. р-т *С* Не вагон  Маса *1.2*  
Дата \_\_\_\_\_ Тип \_\_\_\_\_ Дик. р-т \_\_\_\_\_ Не вагон  Маса \_\_\_\_\_  
Дата \_\_\_\_\_ Тип \_\_\_\_\_ Дик. р-т \_\_\_\_\_ Не вагон  Маса \_\_\_\_\_

Fig. 3.7.

**СЪСТАВ НА ВАГОННАТА БРИГАДА**

Членован вагон	Тип	Година	Конструктор	Тяга	Ст.	Тяга	Редовно т.
<i>Спиралка</i>	<i>С</i>	<i>2022</i>	<i>С</i>	<i>13</i>	<i>15</i>	<i>16</i>	<i>18</i>

**Локомотивна бригада**

Локомотив	Модел	Положение вагон	Дата	Ст.	Тяга	Моб. телефон
<i>Спиралка</i>	<i>С</i>	<i>13</i>	<i>15</i>	<i>16</i>	<i>18</i>	<i>18</i>

**Друг персонал, обслужваща вагон**

Име, фамилия, длъжност	Сутраш	Ст.	Тяга	Моб. телефон	Име, фамилия, длъжност - ПС	Ст.	Тяга

**СЪСТАВ НА ВАГА**

Вид на вагон	Вагон				Секция	Секция	Секция	Секция	Секция	Секция	Секция	Секция	Секция	Секция
	№	Секция	Секция	Секция										
<i>Спиралка</i>	<i>С</i>	<i>13</i>	<i>15</i>	<i>16</i>	<i>18</i>	<i>18</i>	<i>18</i>	<i>18</i>	<i>18</i>	<i>18</i>	<i>18</i>	<i>18</i>	<i>18</i>	<i>18</i>

Копие списък вагон *С* Дик. р-т *С* Маса *1.2* Вагон *13* Дик. р-т *С* Не вагон  Маса *1.2*

Президент *Селян - nn - 8002* Началник *Сидев*

Fig. 3.8.

**УДОСТОВЕРЕНИЕ ЗА СПИРАЧНАТА МАСА**

Гара *Селан - nn - 8002*  
Дата *03.11.2022*  
Вагон № *2613*

Маса на вагон *1.57* t  
Спирален процент *11.5* %  
Необходима спирална маса *183* t

Mg	ABC*		PC**		Забележка
	Спирална маса, t	Оси, бр.	Спирална маса, t	Оси, бр.	
R <i>16</i>	<i>224</i>	<i>16</i>			<i>95</i>
P					
G					

Начална/Останала маса/оси *224 16*  
Допълнителна маса/оси *- -*  
Всичко: налична спир. маса/оси *224 16*

Неплътност на локомотива *0.2* bar/min  
Неплътност на вагона *0.2* bar/min (впр. 0.5 min)  
Вагона натепнал *ДА*  
Дежурен ръководител *Сидев* Извършил пробя *ДА* на спиралките

Забележки: *Ненужно се зачертава*  
\* Автоматична влакова спиралка  
\*\* Реална спиралка

Fig. 3.9.

№ на вагон	Спир. маса	№ на вагон	Спир. маса
<i>20222742422</i>	<i>56</i>		
<i>20222742422</i>	<i>56</i>		
<i>20222742422</i>	<i>56</i>		
<i>20222742422</i>	<i>56</i>		
<i>224 t</i>			
<i>4116</i>			

Fig. 3.10.



### ***3.2. Factual description of the occurred.***

#### ***3.2.1. Immediate sequence of events that led to the accident, including:***

##### ***3.2.1.1. Actions that the involved in the event persons undertook.***

While he was pulling the train from Kaspitchan station and moving it along the interstation on track No. 1 in the direction of Provadiya station, the locomotive driver noticed that the pressure in the main air duct dropped to 0 bar and the train stopped.

The train made an emergency stop at 19:35 p.m., the locomotive driver sent the assistant locomotive driver to check the connections between the locomotive and the first coach, and he contacted the train master on the service mobile phone. At the same moment, the assistant locomotive driver informed the locomotive driver that the train was on fire between the first and second coaches. The two started to uncouple the train between the first and second coaches in order to prevent the fire from spreading to the first coach. After the uncoupling, the locomotive driver tried to start with the locomotive, but found that the voltage in the catenary was switched off, and together with the assistant locomotive driver undertook an uncoupling between the locomotive and the first coach, since the fire had already covered the first coach next to the locomotive. With the help of the passengers, they pushed with their hands the locomotive to a safe distance. The train master notified the national emergency number 112 about the fire.

The transport crew (a train master and a conductor) organized promptly the removal of all the passengers and their luggage from the train to a safe distance.

At 19:41 p.m., the senior train dispatcher and the train dispatcher of the Shumen - Varna section ordered the energy dispatcher to turn off the voltage in the catenary along the Kaspitchan - Provadiya interstation and on both tracks without prior coordination with the locomotive driver, which led to a fire and burning of the first coach as well, associated with risks when performing manual shunting (uncoupling and pushing the locomotive) at a safe distance from the burning coaches.

At the same time, DFT No. 90596 was moving on current track No. 2, which, also due to the disconnection of the voltage in the catenary, stopped at the interstation without notification, since the train dispatcher did not know what cargo the train was carrying.

Two hours later, at 21:45 p.m., the train dispatcher contacted the drivers of FT No. 2613 and DFT No. 90596 on mobile phones and specified their locations.

At 21:47 p.m., it closed the movement of trains on track No. 1 along the Kaspichan - Provadiya interstation.

In order to extinguish the fire in the coaches, two specialized fire trucks of RS FSaCP Novi Pazar and subsequently three more from RS FSaCP Shumen arrived on the spot.

The passengers from the train were assisted by the authorities of RS FSaCP and they were taken from the place of the fire to the Kaspitchan station with the specialized vehicles together with the transport crew. They were taken from Kaspitchan station by buses provided by the BDZ PS EOOD railway undertaking to Varna station, where they arrived around 23:30 p.m.

The RS FSaCP extinguished the fire in the coaches at 00:30 a.m.

At 00:57 a.m., the voltage was applied to the catenary on track No. 2.

##### ***3.2.1.2. Rolling stock and technical facilities functioning.***

Until the time of the accident, the rolling stock of FT No. 2613 (the locomotive and the passenger coaches) were technically sound.

The locomotive crew, which operated locomotive No. 91521080041-2 during the service of FT No. 2613, did not find any failures and damages in the locomotive. The locomotive was manufactured in 2021 at the SIEMENS plant in Germany. The locomotive is regularly registered in the European Vehicle Register (EVR).

The coaches of FT No. 2613 with No. No. 50522974242-2 B4, 50521974003-0 A4, 50522974109-3 B4, 50522974241-4 B4 were in working order, with regular registration in the European Vehicle Register (EVR).

At the Kaspitchan station, the traffic manager on duty has ordered a route through the interlocking RRI type WSSB, exit from the first track for FT No. 2613 to exit the deviation to current track No. 1 for Provadiya station.

The staff on duty at the stations along the route of FT No. 2613 did not notice any irregularities in the movement of the train.

#### *3.2.1.3. Operational system functioning.*

The operational system for managing the train traffic on the main railway line No. 2 along the Shumen - Varna section and between Kaspitchan and Provadiya stations has been functional and has been functioning normally before the accident. The train traffic along the Shumen - Varna section was carried out on a double-track railway line. The two lines track No. 1 and track No. 2 have impersonal train traffic.

During the accident, the operational system for managing the train traffic between Kaspitchan and Provadiya stations in the period from 21:47 p.m. on 03.11.2022 to 00:57 a.m. on 04.11.2022 did not function on both tracks. On track No. 1, it did not function until 16:15 p.m. on 04.11.2022.

*3.2.2. Sequence of the events from the beginning of the occurrence until the end of the rescue services actions:*

#### *3.2.2.1. Undertaken measures for protecting and guarding the event location.*

Around 19:50 p.m., the authorities from the Ministry of Interior- Kaspichan arrived at the place of the accident, and around 20:30 p.m., the authorities of the pre-trial proceedings from the Regional Directorate Shumen of the Ministry of Interior arrived. After clarifying the situation, the area was restricted to outsiders. The bodies of RS FSaCP were allowed to come on the spot to put out the two coaches on fire and the concerned officials of the entities. Media access was restricted.

#### *3.2.2.2. Actions of the emergency rescue services.*

To extinguish the fire in FT No. 2613, around 20:30 p.m., two specialized vehicles of RS FSaCP Novi Pazar and subsequently three more vehicles of RS FSaCP Shumen arrived on the spot.

The passengers from the train and the transport crew were given help, and they were taken from the place of the fire to the Kaspitchan station with the specialized cars of RS FSaCP. Passengers were taken from Kaspitchan station by buses provided by the railway undertaking BDZ PS EOOD. Around 22:30 p.m., the passengers were taken to Varna station.

The fire was extinguished at 00:30 a.m. by the authorities of RS FSaCP.

At 00:57 a.m., voltage was applied to the catenary on current track No. 2. FT No. 2613 remained on track No. 1 with the voltage switched off in the catenary, which had burned out and the contact wire was broken.

#### *3.2.2.3. Actions of the emergency rehabilitation services*

Non applicable.

#### *3.2.2.4. Actions that SE NRIC and "BDZ-Passenger Services" EOOD undertook for restoring the schedule and capacity along the railway line*

On 03.11.2022 at 23:39 p.m., the train dispatcher closed track No. 2 for train traffic along Kaspitchan - Provadiya interstation. In order to release the interstation Kaspitchan - Provadiya track No. 2 from DFT No. 90596, two diesel locomotives No. 98520055096-2 and No. 98520055121-8 departed from Provadiya station at 23:44 p.m. to km 481+300 for withdrawal of DFT No. 90596 at Provadiya station.

After the release of track No. 2 from the train, the traffic was restored at 00:57 a.m., and the fire zone was crossed at a speed of up to 15 km/h.

By order of the pre-trial proceedings authorities, the locomotive and the composition of FT No. 2613 remained on track No. 1, which was guarded by the authorities of the Ministry of Interior. The movement was interrupted and the voltage in the catenary was disconnected due to a burnout of the contact wire.

On 04.11.2022, the following actions were carried out to restore traffic on current track No. 1:

- Diesel locomotive No. 98520055118-4 departed from Provadiya station at 12:34 p.m. – arrived at the accident site at 13:05 p.m., coupled locomotive No. 91521080041-2 of FT No. 2613, departed back to Provadiya station and arrived at 13:38 p.m.;
- Diesel locomotive No. 98520055094-7 departed from Kaspitchan station at 12:47 p.m. – arrived at the accident site at 12:50 p.m., attached the composition of FT No. 2613, departed back to Kaspitchan station and arrived at 13:55 p.m.;
- RSPM No. 99529436027-7 was sent from Kaspitchan station at 14:13 p.m., which, after removing the damage to the catenary, and returned at 16:03 p.m.
- At 16:14 p.m., the voltage was applied to the catenary on track No. 1 and the movement of all the trains and vehicles at scheduled speed was restored.

## 4. Analysis of the event

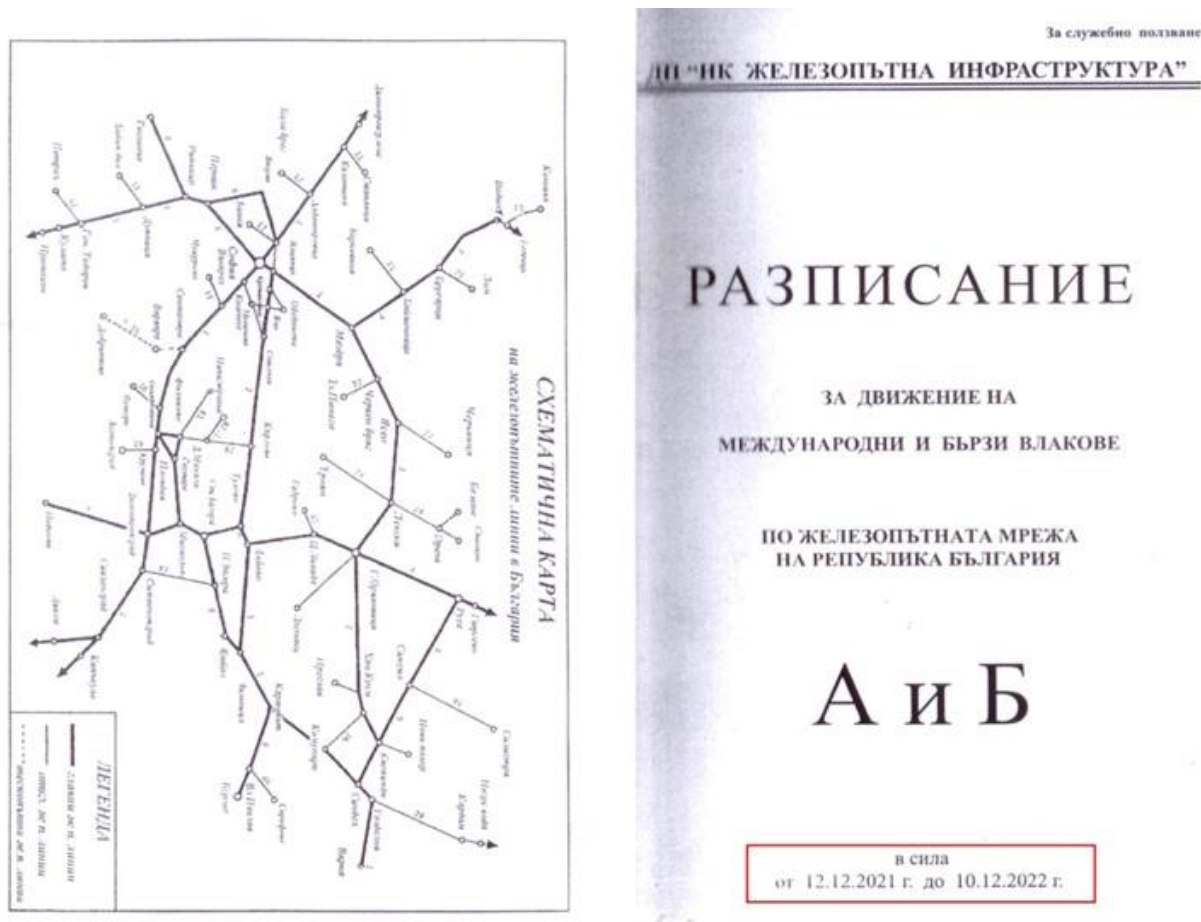
### 4.1. Participation and responsibilities of the entities, involved in the event

#### 4.1.1. Railway undertaking.

Analysis of the movement of FT № 2613.

FT No. 2613 run daily according to the Train operation Schedule (TOS), an extract from which is the Schedule for the movement of international and high-speed trains, parts A and B, in the Republic of Bulgaria in force from 12.12.2021 until 10.12.2022 (Fig. 4.1).

Under schedule the train should depart from Sofia station at 13:15 p.m., and should arrive in Kaspitchan station at 19:28 p.m. (fig. 4.2).



**Fig. 4.1. Covers of Train operation schedule of international and fast trains along the railway network of the Republic of Bulgaria, parts A and B.**

FT № 2613 departed from Sofia station at 13:15 p.m. and arrived in Karnobat station at 19:29 p.m. (fig. 4.4, marker 1). During the movement, the train run normally and kept the travelling times and the operation times.

The data encoding was made from the downloaded records of locomotive № 91521080041-2, headed by FT № 2613 dated 03.11.2022.

The main and most important parameters of the locomotive movement, respectively of the train is registered from the digital speedometer installation system „RED BOX“.

БВ 2612					БДЖ-П	
25.2	120	ПОРДИМ	15	:	-	15:10
6.4		ЖМ 206+900	4	:	-	:14
13.3	115	ПЛЕВЕН	9	15:23	2	:25
2.2	75	ПЛЕВЕН ЗАПАД	3	:	-	:28
5.4	95	ЯСЕН	3	:	-	:31
9.6	110	ДОЛНИ ДЪБНИК	6	:	-	:37
7.9		ГОРНИ ДЪБНИК	5	:	-	:42
11.9		ТЕЛИВЕ	7	149	1	:50
5.2		РП ХУМАТА	4	:	-	:54
12.7	100	ЧЕРВЕН БРЯГ	9	16:03	1	16:04
14.1		КАРЛУКОВО	9	:	-	:13
7.6		КУНИНО	5	:	-	:18
10.1	125	РОМАН	6	:24	1	:25
20.2	130	МЕЗДРА	14	:39	1	:40
2.1	70	МЕЗДРА ЮГ	3	:	-	:43
6.6	80	ЛЮТИ БРОД	5	:	-	:48
3.4	70	РП ЧЕРЕПИШЕ	3	:	-	:51
5.6		ЗВЕРИНО	5	:56	1	:57
6.1		ЕЛИСЕЙНА	5	:	-	17:02
14.5		ЛАКАТНИК	14	:	-	:16
7.7		ВОВ	7	:	-	:23
8.9		СВОГЕ	9	17:32	1	:33
8.8		РЕВРОВО	9	:	-	:42
11.5		КУРИЛО	10	:	-	:52
2.4	100	КУМАРИЦА	3	:	-	:55
5.6	120	ИЛИЯНИ	5	:	-	18:00
2.8	60	СОФИЯ СЕВЕР	4	18:04	1	:05
2.0		СОФИЯ	5	18:10		10224
543.6			429.5		30.5	7ч.40мин.

БВ 2613 400т 115% лок44					БДЖ-П	
2.0	60	СОФИЯ СЕВЕР	5	13:20	1	:21
2.8	70	ИЛИЯНИ	4	:	-	:25
8.0	90	КУРИЛО	10	:	-	:33
11.4	70	РЕВРОВО	9	:	-	:43
8.9		СВОГЕ	8	:51	1	:52
8.9		ВОВ	9	:	-	14:01
7.6		ЛАКАТНИК	7	:	-	:08
14.6		ЕЛИСЕЙНА	13	:	-	:21
6.0		ЗВЕРИНО	5	14:26	1	:27
5.8		РП ЧЕРЕПИШЕ	5	:	-	:32
9.8		МЕЗДРА ЮГ	8	:	-	:40
2.1		МЕЗДРА	3	:43	1	:44
						20112

БВ 2613					БДЖ-П	
5.8	120	ОСЛЕН	5	:	-	14:49
14.3	125	РОМАН	8	:57	1	:58
10.1		КУНИНО	6	:	-	15:04
7.6	100	КАРЛУКОВО	5	:	-	:09
14.1		ЧЕРВЕН БРЯГ	9	15:18	1	:19
12.7		РП ХУМАТА	11	:	-	:30
5.2	110	ТЕЛИВЕ	3	:33	1	:34
11.9		ГОРНИ ДЪБНИК	7	:	-	:41
7.9		ДОЛНИ ДЪБНИК	5	:46	1	:47
9.6		ЯСЕН	6	:	-	:53
5.4	95	ПЛЕВЕН ЗАПАД	4	:	-	:57
2.2	75	ПЛЕВЕН	2	:59	2	16:01
13.3	120	ЖМ 206+900	11	:	-	:12
6.4	115	ПОРДИМ	4	:	-	:16
25.2	120	ЛЕВСКИ	14	16:30	1	:31
20.0		ПАВЛИКЕНИ	13	:44	1	:45
5.3		МЮК. СТАМБОЛ.	4	:	-	:49
4.8	125	ЛЕСИЧЕРИ	2	:	-	:51
4.6	110	РУСАЛЯ ДИЧИН	3	:	-	:54
7.6	125	РЕСЕН	5	:	-	:59
8.5	85	ПОЛИКРАИШЕ	5	:	-	17:04
2.0	105	ПОЛИКРАИШЕ ПЗ	2	:	-	:06
3.0		ГО ПОСТ1	2	:	-	:08
1.5		ГОРНА ОРЯХОВИЦА	2	17:10	10	:20
17.2	110	ДЖУЛНИЦА	13	:	-	:33
10.4	100	СТРАЖИЦА	7	:40	1	:41
10.0		АСЕНОВО	7	:	-	:48
13.2	80	СЛАВЯНОВО	13	:	-	18:01
8.7		ПОПОВО	7	18:08	1	:09
10.2		КАРАДЖАТА	8	:	-	:17
11.3	100	ДРАФФА	7	:	-	:24
18.0	80	ТЪРГОВИЩЕ	14	:38	1	:39
29.3	100	ХАН КРУМ	18	:	-	:57
14.3		ВУМЕН	11	19:08	2	19:10
7.3		МЪТНИЦА	6	:	-	:16
11.4		КАЛУТЕРИЦА	8	:	-	:24
4.1	80	КАСПИЧАН	4	:28	2	:30
29.7		ПРОВАДИЯ	25	:55	1	:56
3.1	60	ДОВРИНА	4.5	20:01	0.5	20:01
17.5		СИНДЕЛ	19	:20	1	:21
6.1	100	РАЗДЕЛНА	5	:	-	:26
3.5		ПОВЕЛЯНОВО	3	:29	1	:30
5.5		БЕЛОСЛАВ	5	:35	1	:36
9.8	80	ЕЗЕРОВО	5	:	-	:41

Fig. 4.2. Schedule of FT № 2613, first part. There are marked the train origin station – Sofia and the train stopping final destination station – Kaspitchan.

БВ 2613					БДЖ-П	
3.6	90	ТОПОЛИТЕ	4	:	-	20:45
6.0	80	ВАРНА ТОВ.ПАРК	5	:	-	:50
3.3		ВАРНА	5	20:55		
543.5			426.5		33.5	7ч.40мин.

БВ 2614 400т 115% лок44					БДЖ-П	
3.3	80	ВАРНА ТОВ.ПАРК	5	:	-	:35
6.0		ТОПОЛИТЕ	5	:	-	:40
3.6	90	ЕЗЕРОВО	3	:	-	:43
5.8	80	БЕЛОСЛАВ	5	13:48	1	:49
5.6	100	ПОВЕЛЯНОВО	5	:54	1	:55
3.4		РАЗДЕЛНА	3	:	-	:58
6.1		СИНДЕЛ	6	:	-	14:04
13.7	60	СОЛНА МИНА	16	:	-	:20
3.8	80	ДОВРИНА	3.5	14:24	0.5	:24
3.2		ПРОВАДИЯ	4	:28	1	:29
29.6		КАСПИЧАН	24	:53	1	:54
4.2		КАЛУТЕРИЦА	4	:	-	:58
11.3	100	МЪТНИЦА	8	:	-	15:06
7.3		ВУМЕН	6	15:12	2	:14
14.3	90	ХАН КРУМ	11	:	-	:25
29.3	100	ТЪРГОВИЩЕ	18	:43	1	:44
18.0		ДРАФФА	14	:	-	:58
11.4		КАРАДЖАТА	7	:	-	16:05
10.2	90	ПОПОВО	7	16:12	1	:13
8.6	80	СЛАВЯНОВО	8	:	-	:21
13.3		АСЕНОВО	13	:	-	:34
9.9	100	СТРАЖИЦА	7	:41	1	:42
10.5		ДЖУЛНИЦА	8	:50	1	:51
17.2	110	ГОРНА ОРЯХОВИЦА	14	17:05	10	17:15
1.5	105	ГО ПОСТ1	3	:	-	:18
3.0		ПОЛИКРАИШЕ ПЗ	3	:	-	:21
2.0		ПОЛИКРАИШЕ	2	:	-	:23
5.5	85	РЕСЕН	4	:	-	:27
22.3	130	ПАВЛИКЕНИ	13	:40	1	:41
10.8	115	БУТОВО	7	:	-	:48
9.2	110	ЛЕВСКИ	6	:54	1	:55
25.2	120	ПОРДИМ	15	:	-	18:10
6.4		ЖМ 206+900	4	:	-	:14
13.3	115	ПЛЕВЕН	9	18:23	2	:25
2.2	75	ПЛЕВЕН ЗАПАД	3	:	-	:28
5.4	95	ЯСЕН	3	:	-	:31
9.6	110	ДОЛНИ ДЪБНИК	6	:	-	:37

БВ 2614					БДЖ-П	
7.9	110	ГОРНИ ДЪБНИК	5	:	-	18:42
11.9		ТЕЛИВЕ	7	149	1	:50
5.2		РП ХУМАТА	4	:	-	:54
12.7	100	ЧЕРВЕН БРЯГ	9	19:03	1	19:04
14.1		КАРЛУКОВО	9	:	-	:13
7.6		КУНИНО	5	:	-	:18
10.1	125	РОМАН	6	:24	1	:25
20.2	130	МЕЗДРА	14	:39	1	:40
2.1	70	МЕЗДРА ЮГ	3	:	-	:43
6.6	80	ЛЮТИ БРОД	5	:	-	:48
3.4	70	РП ЧЕРЕПИШЕ	3	:	-	:51
5.6		ЗВЕРИНО	5	:56	1	:57
6.1		ЕЛИСЕЙНА	5	:	-	20:02
14.5		ЛАКАТНИК	14	:	-	:16
7.7		ВОВ	7	:	-	:23
8.9		СВОГЕ	9	20:32	1	:33
8.8		РЕВРОВО	9	:	-	:42
11.5		КУРИЛО	10	:	-	:52
2.4	100	КУМАРИЦА	3	:	-	:55
5.6	120	ИЛИЯНИ	5	:	-	21:00
2.8	60	СОФИЯ СЕВЕР	4	21:04	1	:05
2.0		СОФИЯ	5	21:10		
543.6			428.5		31.5	7ч.40мин.

БВ 2615 400т 115% лок44					БДЖ-П	
2.0	60	СОФИЯ СЕВЕР	5	15:20	1	:21
2.8	70	ИЛИЯНИ	4	:	-	:25
8.0	90	КУРИЛО	10	:	-	:33
11.4	70	РЕВРОВО	8	:51	1	:43
8.9		СВОГЕ	8	:51	1	:52
8.9		ВОВ	9	:	-	16:01
7.6		ЛАКАТНИК	7	:	-	:08
14.6		ЕЛИСЕЙНА	13	:	-	:21
6.0		ЗВЕРИНО	5	16:26	1	:27
5.8		РП ЧЕРЕПИШЕ	5	:	-	:32
9.8		МЕЗДРА ЮГ	8	:	-	:40
3.1		МЕЗДРА	3	:43	1	:44
5.8	120	ОСЛЕН	5	:	-	:49
14.3	125	РОМАН	8	:57	1	:58
10.1		КУНИНО	6	:	-	17:04
7.6	100	КАРЛУКОВО	5	:	-	:09
14.1		ЧЕРВЕН БРЯГ	9	17:18	1	:19

Fig. 4.3. Schedule of FT № 2613 – second part. Final destination station of the train – Varna.



The registered data are separated into two packages: analogue and digital. The following parameters are used within reading the data (fig. 4.4):

- Analogue data:
  - Speed of movement (km/h): position 1, marked in red colour;
  - Pressure in the main air duct: position 2 (the meanings are presented in Table 4.1), marked in blue colour:

**Table 4.1**

<b>Registration of the chart</b>	<b>Drivers brake valve status</b>	<b>Pressure in the main air duct [bar]</b>
0	Impact filling	>5.0
1	Travelling (fully charged and loose brake) 1A	5.0
2	Last degree of loosening 1B	4.8
3	First degree arrest	4.6
4	Second degree arrest	4.4
5	Third degree arrest	4.28
6	Fourth degree arrest	4,15
7	Fifth degree arrest	4,0
8	Sixth degree arrest	3,85
9	Seventh degree arrest	3,7
10	Full arrest	3,5
11	Fast arrest	<3.2

- Pressure in the brake cylinders: positions 3 and 4 (activated from the direct brake of the locomotive, the meanings are given in Table 4.2), marked with light blue colour;

**Table 4.2**

<b>Registration in the diagram</b>	<b>Pressure in the brake cylinders [bar]</b>
0	0-0.21
1	0.22-0.75
2	0.76-1.25
3	1.26-1.75
4	1.76-2.25
5	2.26-2.75
6	2.76-3.25
7	>3.26

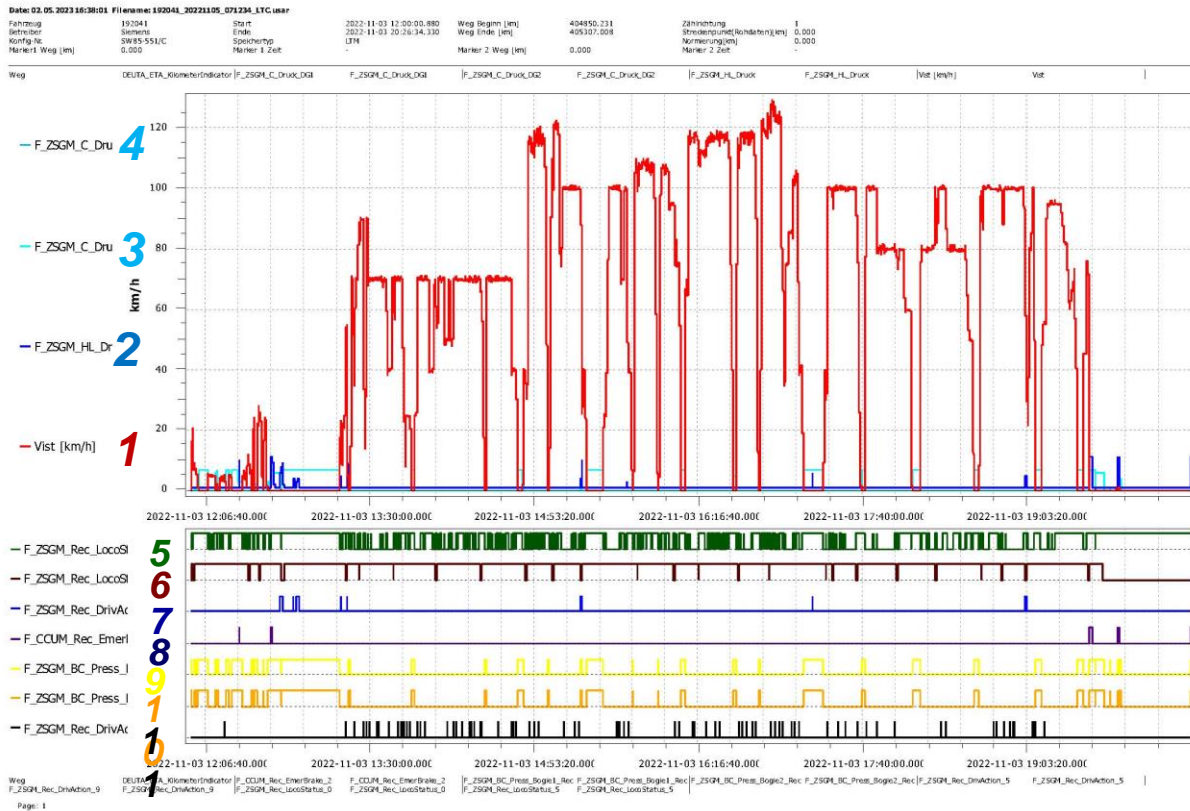


Fig. 4.4.

- Digital data:
  - Information on applied traction force: position 5, green color, (F\_ZSGM\_Rec\_Loco Status\_0); indications: 0 – traction mode; 1 – lack of traction mode (runout);
  - Information on the applied electro-dynamic halt: position 6, dark red color, (F\_ZSGM\_Rec\_LocoStatus\_7); indications: 1 – presence of electro-dynamic halt; 0 – lack of electrodynamic halt;
  - Information on activating the automatic pneumatic brake from the brake valve (F\_ZSGM\_Rec\_DrivAction\_5): position 7, blue color;
  - Information on the emergency activating of the pneumatic brake without activation of the brake valve (F\_CCUM\_Rec\_Emerbrake\_2): position 8, dark blue color;
  - Information on the emergency activation of the pneumatic brake of the first bogie : position 9, yellow color;
  - Information on the emergency activating of the second bogie: position 10, orange color;
  - Information on the activated air sound signal (F\_ZSGM\_Rec\_DrivAction\_9): position 11, black color.

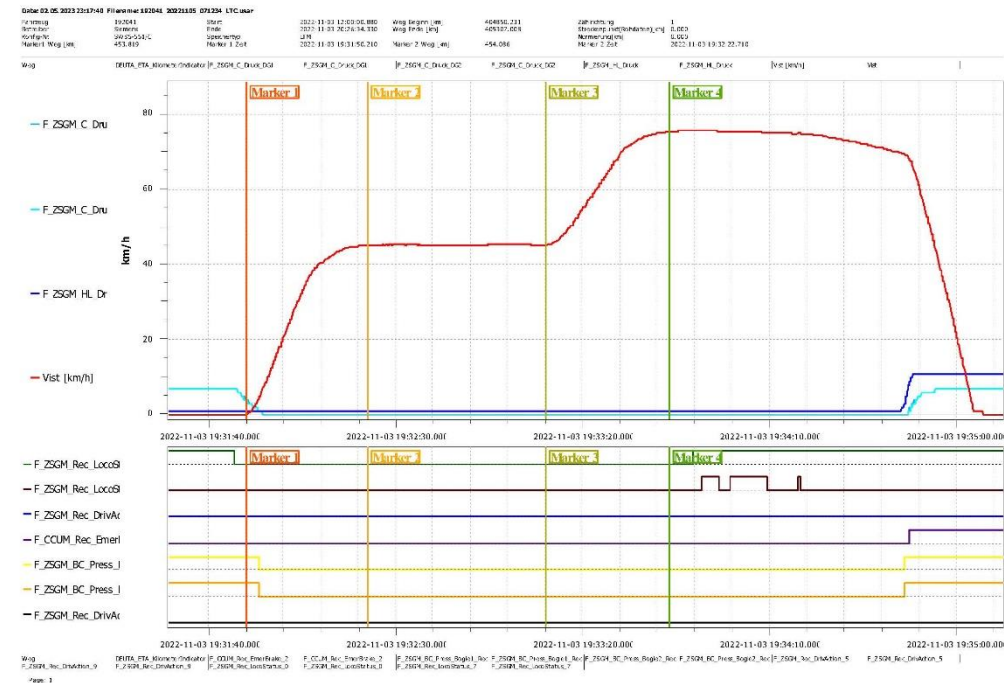
The analysis of the movement of FT No. 2613 was carried out from the stop at Kaspitchan station to the stop of the train after the accident occurred.

FT No. 2613 arrived at Kaspitchan station at 19:29:01 p.m., and the stop was made with the electrodynamic brake (Fig. 4.4, marker 1). It remained until 19:31:50 p.m. for 2 minutes and 49 seconds (Fig. 13, marker 1 - marker 2).



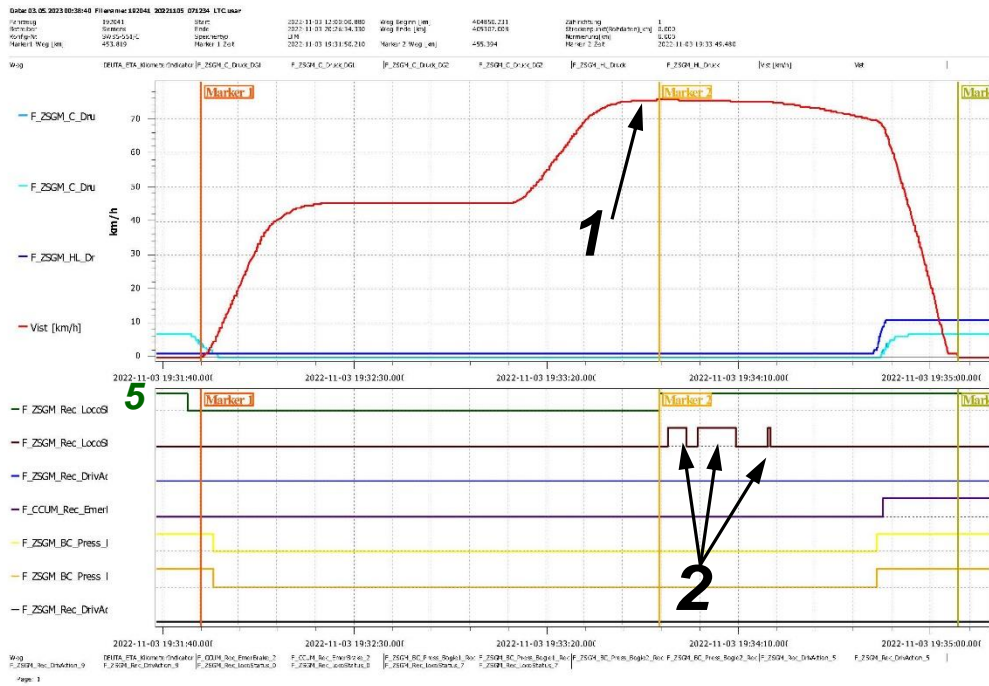
**Fig. 4.4.**

At 19:31:50 p.m. it started (Fig. 4.5, marker 1) and accelerated to 45.1 km/h for 267 meters in 32.5 seconds (Fig. 4.5, marker 2), then travelled 599 meters for 47, 48 seconds at an almost constant speed (45 km/h), moving in traction mode, apparently with a reduced value of the traction force (Fig. 4.5, marker 3).



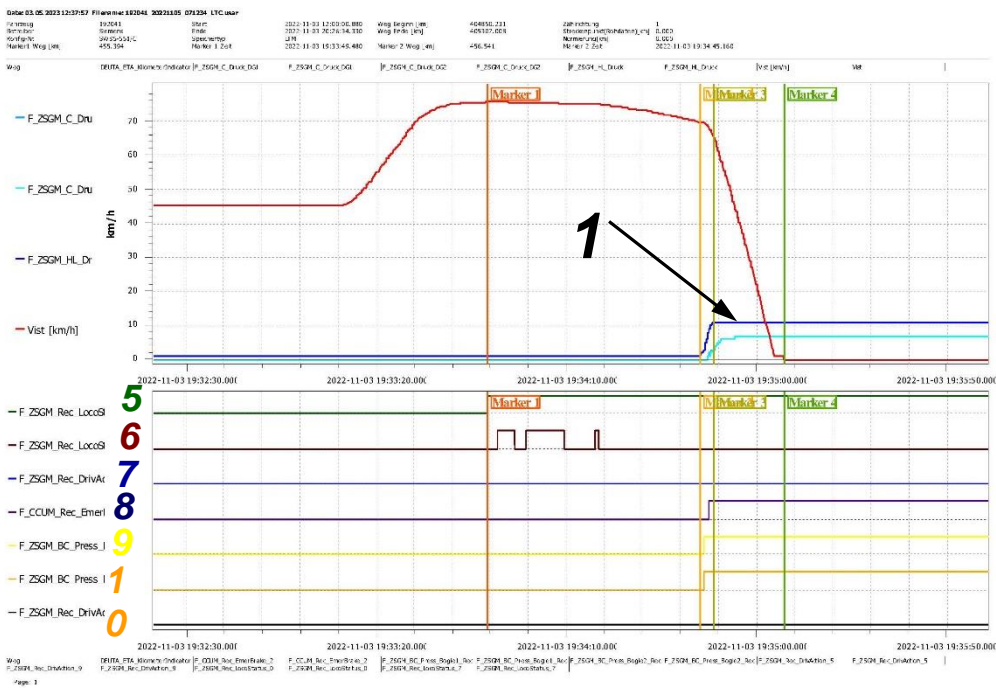
**Fig. 4.5.**

At 19:33:10 p.m. the speed began to increase again due to an increase in the traction force, with the train accelerating to 75.3 km/h, traveling 579 meters in 30.1 seconds (Fig. 4.5, marker 4). From this point on, the speed varied within narrow limits, although the locomotive continued to move in traction mode, apparently again with a reduced traction force (Fig. 4.6, item 1).



**Fig. 4.6.**

At km 460+677, after it had passed 1575 meters from its departure from Kaspitchan station,



**Fig. 4.7.**

within speed 75,5 km/h the locomotive driver switched off the traction mode and the locomotive switched in a runout mode in order to pass the neutral insert of the catenary (fig. 4.6, marker 2, line 5 in the digital chart). It happened at 19:33:49 p.m. From that moment on the speed started to decrease gradually from



the natural resistance during the movement of the train and the activation of the electrodynamic brake several times (Fig. 4.5, item 2), reaching a value of 69.6 km/h (Fig. 4.7, marker 2).

At 19:34:45 p.m. at a speed of 69.6 km/h, when the train was located at km 461+824, the automatic train brake was activated (Fig. 4.7, marker 2, analogue part, the blue line, position 1) and the pressure in the main air duct began to decrease, reaching a value of 11 (below 3.2 bar - fig. 4.7, marker 3, blue line on the analogue chart). The activation was carried out by the train without the use of the brake valve (Fig. 4.7, between marker 2 and marker 3, line 7): the analogue chart recorded the pressure change in the main air duct, position 1, and the digital one recorded the pressure change in the main air duct, line 8 and the change in pressure in the brake cylinders of the two bogies, lines 9 and 10. At 19:34:46 p.m. (Fig. 4.7, between marker 1 and marker 2) the speed began to decrease sharply and at 19:35: 07 p.m. after traveling 229 meters (Fig. 4.7, marker 4) it reached a value of 0 km/h and the train settled at a location at km 462+045 (at the location of the front buffers of the locomotive before it was uncoupled from the train).

*Analysis of the causes that led to the accident occurrence.*

The Investigation Commission carried out several inspections of the burning coaches both at the place of the accident along Kaspitchan - Provadiya interstation at km 462+000 (fig. 4.8) and at the Gorna Oryahovitsa wagon depot, where they were settled in a garage (fig. 4.9 and 4.10 ).

The Investigation Commission also visited the Nadezhda wagon depot several times, where it additionally examined the structure of a coach of the same series along with the location of the most important and vulnerable nodes and elements of the electrical installations and equipment in the coach.



**Fig. 4.8.**





**Fig. 4.9.**

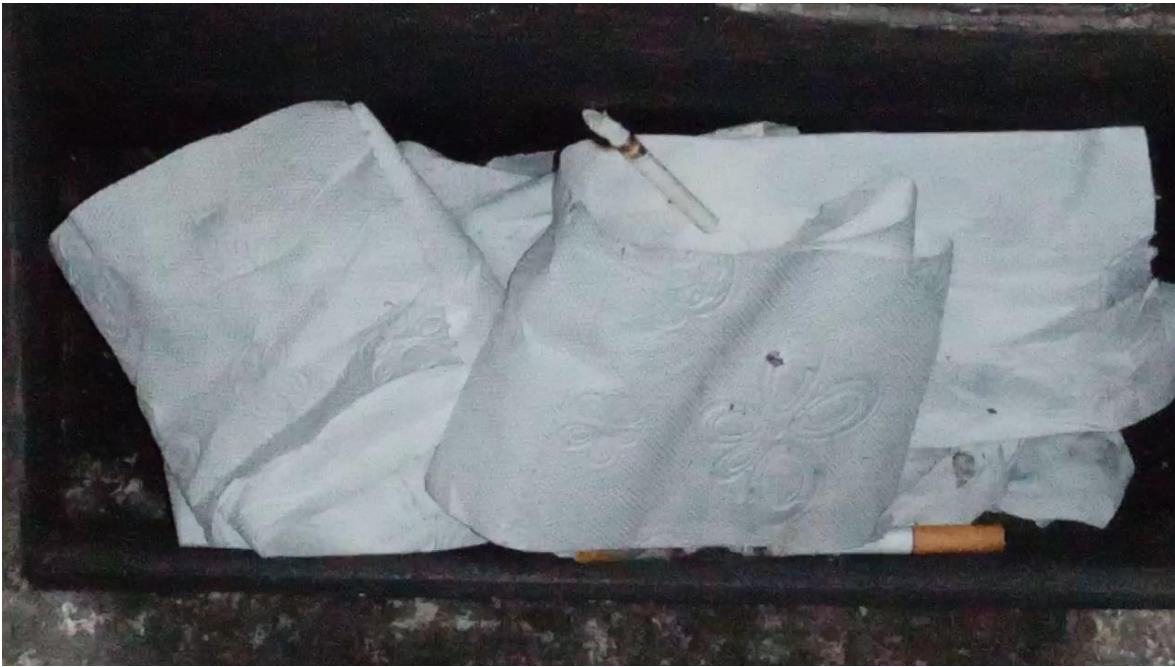


**Fig. 4.10.**

Based on the clues found at the ignition site, it was established that the source was located in the area of the first toilet in the direction of travel of the second coach of the train (the first-class coach No. 50521974003-0 - Fig. 4.10).

During the inspections, all possible options were investigated and analysed, including intentional or unintentional ignition from an external source of the toilet paper in the bin. The last version was categorically rejected after experiments involving elements of the sanitary unit device (Fig. 4.11).

Therefore, the cause of the ignition had to be sought in some node of the electrical system of the



**Fig. 4.11.**

coach.

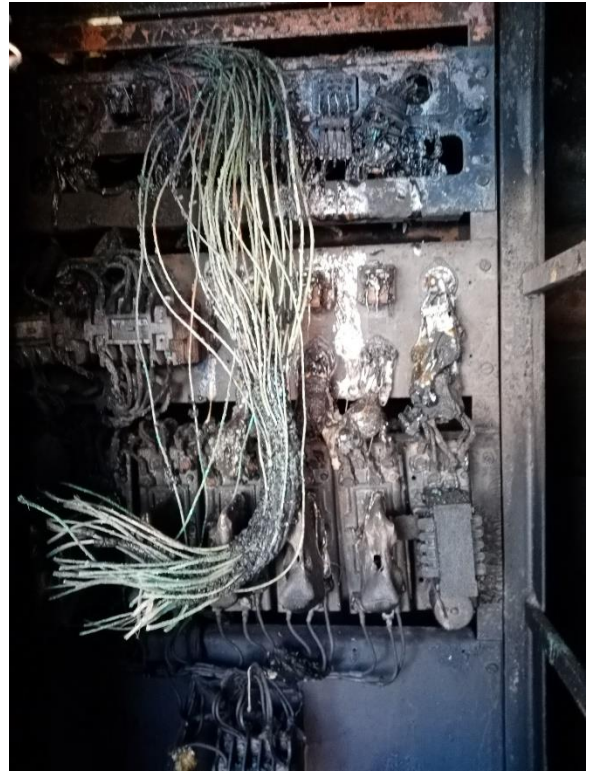
The commission examined and analysed the condition of the most important components of the electrical system of the coach, namely:

- **Apparatus cabinet** –the apparatus cabinet was burnt, but all indications were that it was due to smoke saturation and the burns caused by an elevated outside temperature, with all the fuses on, i.e. the possibility that it triggered one of the protections of the electrical system was ruled out, especially since the apparatus cabinet was located at the opposite end of the coach (fig. 4.12 and 4.13);
- **High voltage charge of the coach** – these cabinets are located under the frame of the coach, and are designed to provide primary power for the electrical system of the coach: for heating 1500 V and for lighting 24 V. During the inspections, it was found that the batteries providing power in the absence of external voltage were clean, were in working order and were not affected by the fire (Fig. 4.14). It was also found that the apparatus cabinet, which housed the apparatus for powering the electrical system of the coach, was in working order, clean and not affected by the fire (Fig. 4.15)
- **Loudspeaker system of the coach** –during the inspections, a bundle of cables was found, feeding the coach's speaker system. The probability that the cause of the ignition was located in that node was minimal, for two reasons:
  - the voltages and currents flowing in them are small;
  - The system has not been supplied with voltage, i.e. no currents flowed in it. During the inspections, it was found that the burns on these cables were external and their fuses were strong and did not activate;





**Fig. 4.12.**



**Fig. 4.13.**



**Fig. 4.14.**



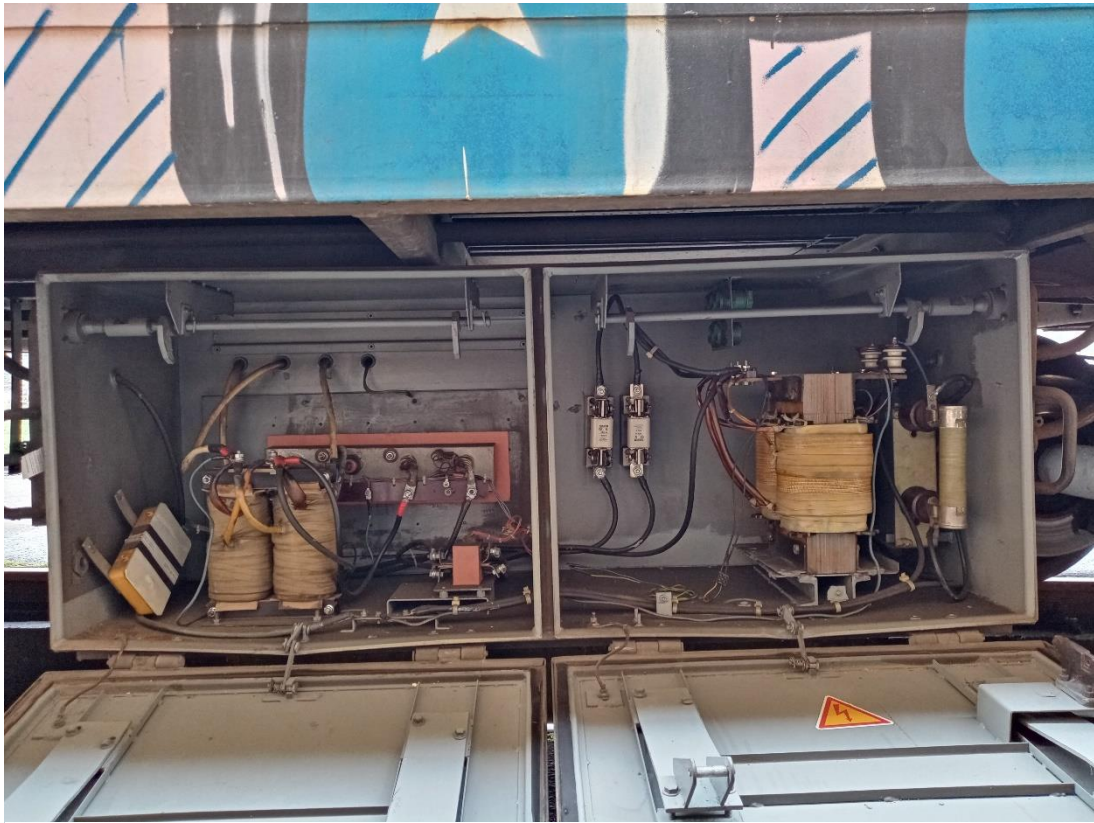


Fig. 4.15.

- **Devices for controlling the toilet unit** - the water in the toilet unit (toilet and wash basin) is controlled using electric buttons that activated electrohydraulic valves. The commission examined

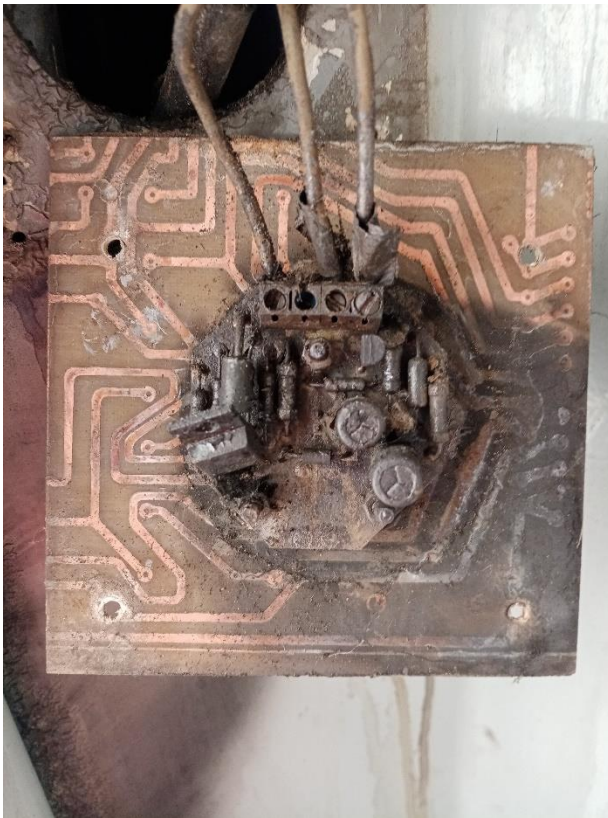


Fig. 4.16.

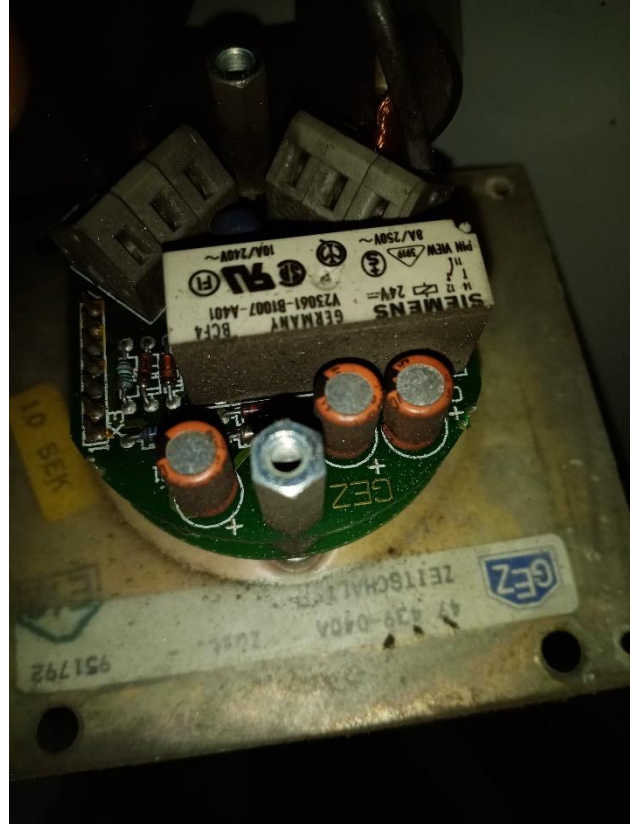


Fig. 4.17.

the device and functions of the control buttons, as well as the condition of the buttons in the burned coach No. 50521974003-0 and found that the probability of ignition from them was minimal. These buttons were activated relatively rarely and their duration of operation was short – on the order of a few seconds (20 seconds for the sink and 15 for the toilet). It is necessary to add that very small currents passed through them (of the order of 0.4-0.5 A), as well as the fact that when inspecting that node at the opposite end of the burned coach and in other coaches no traces of heating and operation with increased currents and temperatures were found (Fig. 4.16, 4.17, 4.18);



**Fig. 4.18.**

- **Water tank heater** - that tank was located directly under the roof of the coach and it stored water for the toilet unit - toilet and sink. It is one of the largest consumers of electrical current and a potential source of ignition. It is powered by a voltage of 220 V and a current of about 0.2 A flows through it. The Investigation Commission carried out detailed inspections of the burned coach and found that its tank was not equipped with a heater, therefore, in that case, the cause was automatically eliminated (Fig. 4.19);
- **Lighting fixtures installed in the entrance part of the coach** - powered by 24 V direct current. The lighting fixtures themselves work with a voltage of 220 V alternating current. An inverter is used to convert the current and voltage (Fig. 4.20). It is necessary to emphasize that the accident occurred during the dark part of the day, which means that the lighting was working, i.e. the lighting fixtures were under voltage and their nominal current passed through them. The Investigation Commission carried out a detailed examination of the lighting fixtures located in the area of the initial ignition, as well as the same fixtures installed in other coaches. Since the diagrams of the power units and elements of the lighting fixtures were not found, they were made by members of the commission on

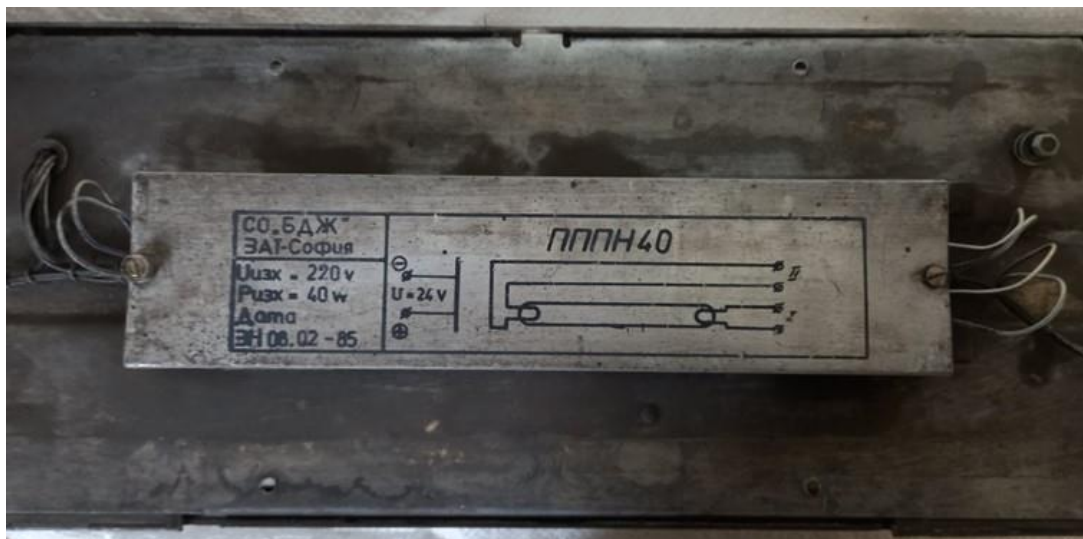


the basis of existing bodies of identical coaches (Fig. 4.21). During the inspection of the power modules of the lighting fixtures, the following features were found.



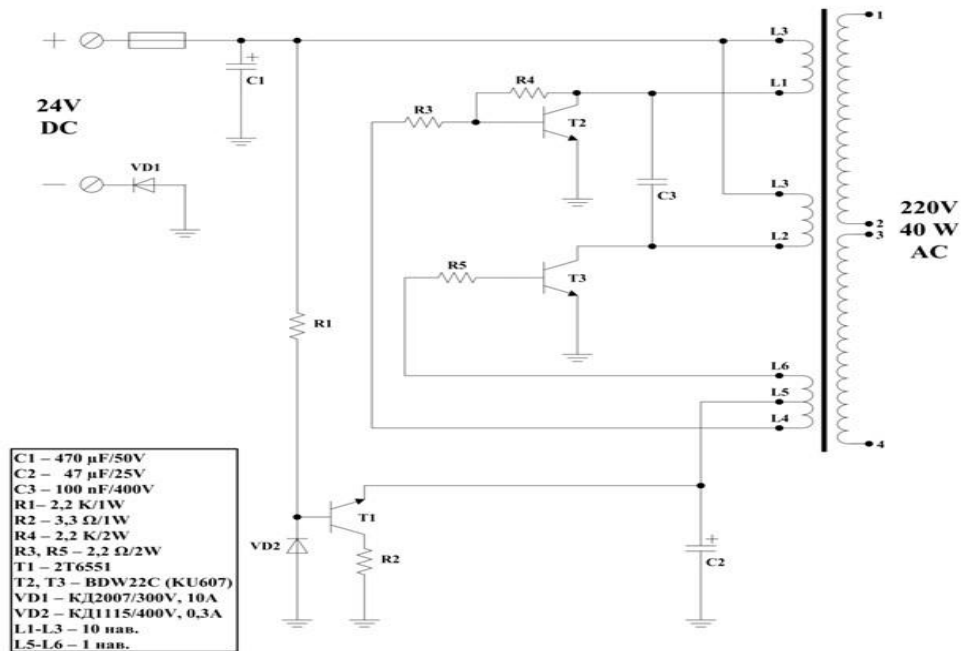
**Fig. 4.19. The arrow shows the outlet in which the heater is installed. In the specific case the outlet is closed with plug, because no heater was installed.**

- In the area of connection of resistors R3 and R5 to the board, unacceptable overheating was detected, detected by the dark brown colour at the soldering points and under the resistors themselves (Fig. 4.22, pos. 1 and 2)

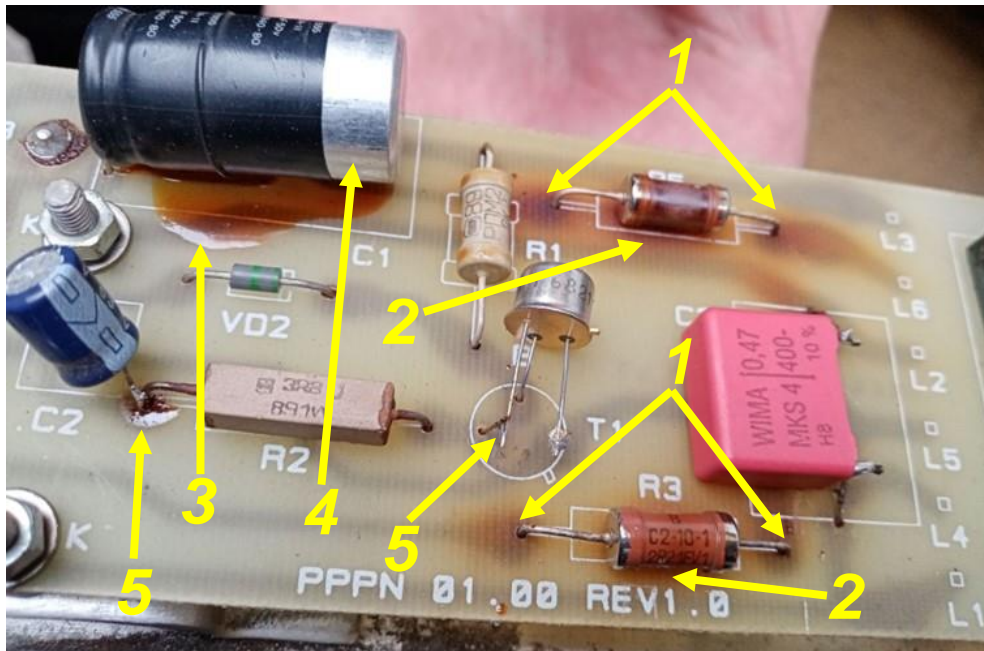


**Fig. 4.20. Inverter for powering the heating fixtures.**

- The Condenser C1 has apparently punctured and its electrolyte has leaked (fig. 31, item 3) and its aluminium housing has moved out of the black insulating body (fig. 31, item 4).
- During the inspection, it was found that when replacing individual elements of the power board, soldering was not done in the holes of the board (which is the correct way of soldering), but to the terminals of the removed damaged elements (fig. 4.22, pos. 5, Fig. 4.23, item 1).
- A strong scalding of the hole for attaching the board to the power supply unit housing was found. That again was a sign of large currents flowing, and heating to high temperatures (Fig. 4.23, item 2).

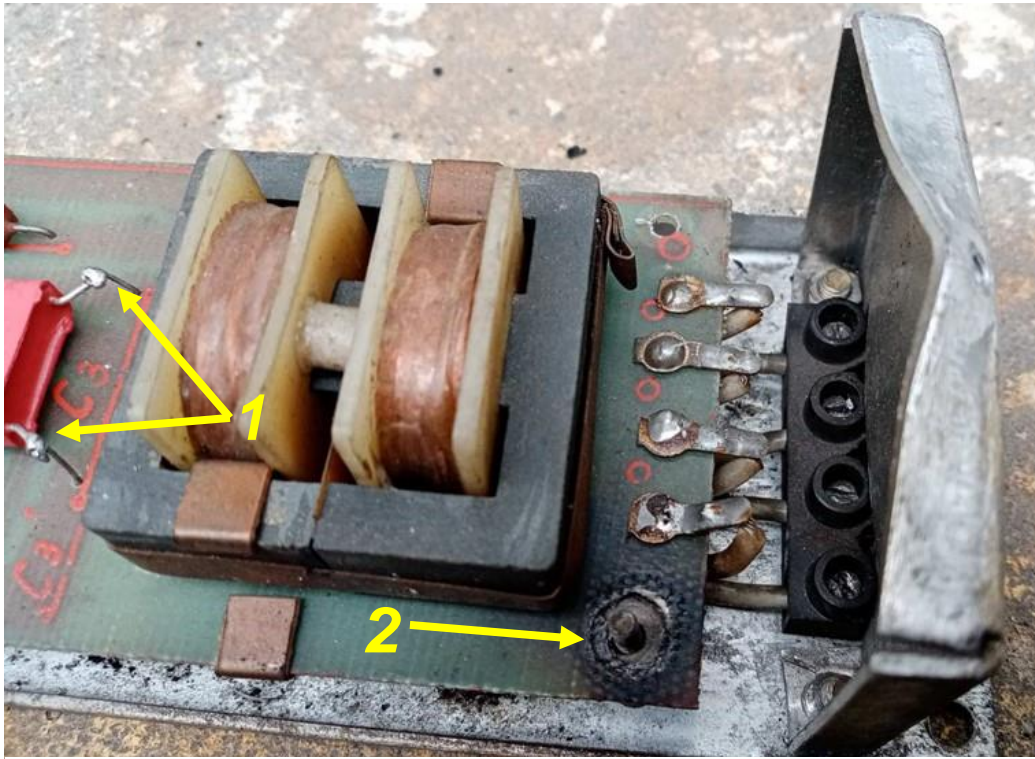


**Fig. 4.21. Electronic chart of the inverter, which powers the lighting fixtures.**



**Fig. 4.22. Power supply board**





**Fig. 4.23. Power supply unit board**

- During the installation of the light fixture, the bundle of wires was not bandaged, but was also painted with white paint, which on the one hand impaired their normal heat exchange, and on the other hand led to a deterioration of their insulating qualities due to the aggressive components contained in the paint (Fig. 4.24).



**Fig. 4.24. Lighting fixture**

The following conclusions can be drawn from the inspections performed and the analysis of the power inverter unit of the lighting fixtures in the area of the entrance space and the toilet unit of the coach:

As a result of errors in carrying out the repairs of the lighting fixtures and installing unsuitable elements in them, the temperature in the power unit rose unacceptably, which led to the melting and ignition of the elements themselves and their insulation, which caused the ignition of the coach.

No other malfunctions were found on the coaches and locomotives of FT No. 2613, which could be the cause of the accident.

*4.1.2. Infrastructure manager.*

*Analysis of the railway infrastructure condition.*

Non applicable.

*4.1.3. Entities in charge of the technical maintenance.*

"BDZ-Passenger Services" EOOD owns the Certificate of Entity in charge of maintenance No BG /31/0021/ 0001, valid from 19.04.2021 to 18.04.2026;

SE NRIC has a Certificate of Entity in charge of maintenance with UIN BG /31/0020/ 0003, valid from 01.07.2020 to 30.06.2025.

SE NRIC has a Certificate of Entity in charge of maintenance of railway vehicles with UIN BGRA 2020/0004, valid from 01.07.2020 to 16.06.2023.

*4.1.4. Manufacturers or providers of rolling stock and railway products.*

Non applicable.

*4.1.5. National Safety Authority.*

Railway Administration Executive Agency is the National Safety Authority for railway transport in the Republic of Bulgaria.

*4.1.6. Notified bodies or Risk assessment bodies.*

Non applicable.

*4.1.7. Certifying bodies of the entities in charge of maintenance.*

The Railway Administration Executive Agency as the National Safety Authority for railway transport performs certification of the entities in charge of the vehicles maintenance (ECM) in accordance with Directive 2004/49/EC and Regulation (EU) 445/2011, as per Ordinance No 59 on the railway transport safety management and on the maintenance functions in accordance with Directive 2004/49/EC and Regulation (EU) 445/2011.

From June 16, 2020 the RAEA performs certification of the ECM as per the Commission Implementing Regulation (EU) 2019/779 of 16 May 2019 laying down detailed provisions on a system of certification of entities in charge of maintenance of vehicles pursuant to Directive (EU) 2016/798 of the European Parliament and of the Council and repealing Commission Regulation (EU) No 445/2011.

*4.1.8. Persons or entities involved in the event, documented or not in the respective safety management systems or indicated in register.*

- SE NRIC implements Safety Procedure SP 2.09 "Methodology for determining, assessing and managing of the risk" version 05 effective from 01.03.2019, part of the SMS.

- BDZ PS EOOD implements Quality Procedure QP-2-15 "Safety Management of Passenger Transportation. Monitoring and information" from 13.12.2018 and Methodology for assessing the safety risk in BDZ PS EOOD from 23.02.2012. Hazards register during the operation, repair and maintenance of RRS at „BDZ-Passenger services“ EOOD.

*4.2. Rolling stock and technical facilities:*

*4.2.1. Factors, deriving from the design of the rolling stock, railway infrastructure or technical facilities.*

Non applicable.

4.2.2. *Factors deriving from the installation and placing into service of the rolling stock, railway infrastructure and technical facilities.*

Non applicable.

4.2.3. *Factors deriving from manufacturers or another provider of railway products.*

Non applicable.

4.2.4. *Factors, deriving from the technical maintenance and/or modification of the rolling stock or the technical structures.*

Non applicable.

4.2.5. *Factors due to the entity in charge of the technical maintenance, workshops for technical maintenance and other technical maintenance service providers.*

Non applicable.

4.2.6. *Other factors or consequences considered as involved within the investigation objectives.*

Non applicable.

### **4.3. Human factor:**

4.3.1. *Individual human characteristics:*

4.3.1.1. *Training and development, including skills and experience.*

#### Railway undertaking:

- Locomotive driver of locomotive № 91521080041-2 – License № 11501 for obtaining professional qualification for „Locomotive driver of electrical locomotives“, training performed within the period 05.10.÷10.12.2009, training institution PTC BDZ – Sofia, issued by RAEA;

Locomotive driving license BG 71 2017 0741, issued by RAEA;

License № VII-1028 for position, Locomotive driver“ in BDZ PS EOOD dated 22.02.2021.

Additional certificate № 000002526679 from BDZ PS EOOD for rolling stock for which is permitted the driver to handle – series 43, 44, 45, 46200 and 80.000 dated 15.03.2022 along the national railway infrastructure of the Republic of Bulgaria until 14.03.2025.

- Assistant locomotive driver of locomotive № 91521080041-2 – License № 21361 for obtaining professional qualification for „Assistant locomotive driver“, training performed within the period 20.08.2018÷12.12.2018, training institution PTC BDZ – Sofia, issued by RAEA.

License № VII-947 for position, Assistant locomotive driver“ in BDZ PS EOOD dated 22.01.2021.

- Train master, passenger traffic of FT № 2613 – License № 16067 for obtaining professional qualification for „Train master“, training performed within the period 03.02.2014 ÷ 10.04.2014, training institution Professional Training Centre (PTC) of Bulgarian State Railways (BDZ), issued by RAEA;

License № VI-238 for position Train master, passenger traffic at BDZ PS EOOD dated 14.07.2020.

- Conductor of FT № 2613 – License № 24087 for obtaining professional qualification for „Conductor“, training performed within the period 24.01.2022 ÷ 25.03.2022, training institution Professional Training Centre (PTC) of Bulgarian State Railways (BDZ), issued by RAEA;

License № VI-445 for position Conductor at BDZ PS EOOD dated 13.06.2022.

#### Railway infrastructure:

- Senior dispatcher at ZOD Gorna Oryahovitsa on shift 03/04.11.2022– Diploma № 001565/28.07.2000, „Technology and organization of the railway transport“ with professional qualification „Traffic manager in the rail transport“, training performed within the period 1917 ÷ 2000, issued by MNHT „Todor Kableshkov – Sofia;

License № 4180 for the position senior dispatcher on shifts at TOSAMD Gorna Oryahovitsa within SE NRIC dated 31.08.2021.

- Train dispatcher at ZOV Gorna Oryahovitsa on shift 03/04.11.2022– Diploma № 000640/14.08.1993 г., with qualification „Technology and organization of the railway transport” with



professional qualification „Traffic manager and trade operation transport“, training performed within the period 1990 ÷ 1993, issued by PRI „Todor Kableshkov – Sofia;

License № 3458 for the position Train dispatcher at TOSAMD Gorna Oryahovitsa within SE NRIC dated 29.12.2017.

- Energy dispatcher at REU Gorna Oryahovitsa on shift 03/04.11.2022. License № 8471 for obtained qualification for „Mechanic catenary“, training performed within the period 27.09.÷12.11.2021, training institution PTC at SE NRIC;

License № 89 for the position energy dispatcher at REU Gorna Oryahovitsa at TOSAMD Gorna Oryahovitsa dated 01.08.2007.

- Traffic manager at Kaspitchan station first person – Diploma № 000351/01.03.1996, with qualification „Technology and organization of the railway transport, with professional qualification „Traffic manager and trade operation transport“, training performed within the period 1992 ÷ 1996, issued by MNHT „Todor Kableshkov – Sofia;

License № 2577 for the position Traffic manager at TOSAMD Gorna Oryahovitsa dated 15.06.2011.

- Traffic manager at Kaspitchan station second person – License № 16731 for obtained qualification for „Traffic manager“, training performed within the period 28.01.÷30.07.2014, training institution PTC at SE NRIC, issued by RAEA;

License № 3759 for the position Traffic manager at TOSAMD Gorna Oryahovitsa dated 30.01.2019.

- Traffic manager at Provadiya station – License № 8981 qualification „Traffic manager and trade operation transport“, training performed within the period 20.09.1982÷22.07.1983, training institution SO BDZ – Gorna Oryahovitsa;

License № 1686 for the position Traffic manager at TOSAMD Gorna Oryahovitsa dated 04.09.2007.

*4.3.1.2. Medical and personal circumstances, which influence the event, including the presence of physical and psychological stress.*

Railway undertaking:

- Locomotive driver of locomotive № 91521080041-2:

Periodic medical exam card dated 27.10.2022, issued by National multi-profile transport hospital Gorna Oryahovitsa.

Conclusion: suitable for locomotive driver.

Psychological certificate № 1070/10.10.2022, issued by Psychological laboratory on railway transport – Gorna Oryahovitsa for locomotive driver.

Conclusion: allowed for a period of 5 years.

- Assistant locomotive driver of locomotive № 91521080041-2:

Periodic medical exam card dated 23.06.2022 issued by National multi-profile transport hospital Gorna Oryahovitsa.

Conclusion: suitable for Assistant locomotive driver.

Psychological certificate № 547/07.06.2018, issued by Psychological laboratory on railway transport – Gorna Oryahovitsa for assistant locomotive driver.

Conclusion: allowed for a period of 5 years.

- Train master, passenger traffic of FT № 2613:

Periodic medical exam card dated 29.12.2022 issued by National multi-profile transport hospital Gorna Oryahovitsa.

Conclusion: suitable for train master, passenger traffic.

Psychological certificate № 587/15.07.2020, issued by Psychological laboratory on railway transport – Gorna Oryahovitsa for train master.

Conclusion: allowed for a period of 5 years.

- Conductor of FT № 2613:

Periodic medical exam card dated 13.06.2022 issued by National multi-profile transport hospital Gorna Oryahovitsa.

Conclusion: suitable for conductor.

Railway infrastructure:

- Senior dispatcher on shift at ZOD – Gorna Oryahovitsa:

Periodic medical exam card dated 07.12.2021 issued by National multi-profile transport hospital Gorna Oryahovitsa.

Conclusion – suitable for senior dispatcher.

Psychological certificate № 2/09.01.2018 issued by Psychological laboratory on railway transport – Gorna Oryahovitsa for senior dispatcher.

Conclusion: allowed for a period of 5 years.

- Train dispatcher at ZOV – Gorna Oryhovitsa:

Periodic medical exam card dated 26.11.2021 issued by National multi-profile transport hospital Gorna Oryahovitsa.

Conclusion: suitable for train dispatcher.

Psychological certificate № 996/30.10.2018 issued by Psychological laboratory on railway transport – Gorna Oryahovitsa for train dispatcher.

Conclusion: allowed for a period of 5 years.

- Energy dispatcher at REU – Gorna Oryahovitsa:

Periodic medical exam card dated 16.12.2021 issued by National multi-profile transport hospital Gorna Oryahovitsa.

Conclusion: suitable for energy dispatcher.

Psychological certificate № 1011/28.11.2017 issued by Psychological laboratory on railway transport – Gorna Oryahovitsa for energy dispatcher.

Conclusion: allowed for a period of 5 years.

- Traffic manager Kaspitchan station first person:

Periodic medical exam card dated 01.06.2022 issued by National multi-profile transport hospital Gorna Oryahovitsa.

Conclusion: suitable for traffic manager.

Psychological certificate № 1167/24.11.2020 issued by Psychological laboratory on railway transport – Gorna Oryahovitsa for traffic manager.

Conclusion: allowed for a period of 5 years.

- Traffic manager Kaspitchan station second person:

Periodic medical exam card dated 30.05.2022 issued by National multi-profile transport hospital Gorna Oryahovitsa.

Conclusion: suitable for traffic manager.

Psychological certificate № 160/15.02.2020 issued by Psychological laboratory on railway transport – Gorna Oryahovitsa for traffic manager.

Conclusion: allowed for a period of 5 years.

- Traffic manager Provadiya station:

Periodic medical exam card dated 02.06.2022 issued by National multi-profile transport hospital Gorna Oryahovitsa.

Conclusion: suitable for traffic manager.

Psychological certificate № 454/19.04.2022 issued by Psychological laboratory on railway transport – Gorna Oryahovitsa for traffic manager.

Conclusion: allowed for a period of 3 years.

*4.3.1.3. Fatigue.*

Railway undertaking:

- Locomotive driver of locomotive № 91521080041-2:

Rest: from 02.11.2022 hour 20 minutes 55 until date 03.11.2022 hour 16 minutes 40

Started work on 03.11.2022 hour 16 minutes 40 – (19 hours and 45 min.)

- Assistant locomotive driver of locomotive № 91521080041-2:

Rest: from 02.11.2022 hour 20 minutes 55 until date 03.11.2022 hour 16 minutes 40

Started work on 03.11.2022 hour 16 minutes 40 – (19 hours and 45 min.)

- Train master, passenger traffic of FT № 2613:

Rest: from 02.11.2022 hour 20 minutes 34 until date 03.11.2022 hour 09 minutes 30

Started work on 03.11.2022 hour 09 minutes 30 – (12 hours and 56 min.)

- Conductor of FT № 2613:

Rest: from 02.11.2022 hour 19 minutes 35 until date 03.11.2022 hour 09 minutes 30

Started work on 03.11.2022 hour 09 minutes 30 – (13 hours and 55 min.)

#### *Railway infrastructure:*

- senior dispatcher at ZOD Gorna Oryahovitsa:

Rest: from 02.11.2022 hour 19 minutes 00 until date 03.11.2022 hour 19 minutes 00

Started work on 03.11.2022 hour 19 minutes 00 – (24 hours and 00 min.)

- Train dispatcher at ZOD Gorna Oryahovitsa:

Rest: from 02.11.2022 hour 19 minutes 00 until date 03.11.2022 hour and 19 minutes 00

Started work on 03.11.2022 hour 19 minutes 00 – (24 hour and 00 min.)

- Energy dispatcher at REU Gorna Oryahovitsa:

Rest: from 02.11.2022 r. hour 19 minutes 00 until date 03.11.2022 hour 19 minutes 00

Started work on 03.11.2022 hour 19 minutes 00 – (24 hours and 00 minutes.)

- Traffic manager at Kaspitchan station first person:

Rest: from 02.11.2022 hour 19 minutes 00 until date 03.11.2022 hour 19 minutes 00

Started work on: 03.11.2022 hour 19 minutes 00 – (24 hours and 00 minutes)

- Traffic manager Kaspitchan station second person:

Rest: from 02.11.2022 hour 19 minutes 00 until date 03.11.2022 hour 19 minutes 00

Started work on 03.11.2022 hour 19 minutes 00 – (24 hours and 00 min.)

- Traffic manager Provadiya station:

Rest: from 02.11.2022 r. hour 19 minutes 00 until date 03.11.2022 hour 19 minutes 00

Started work on 03.11.2022 hour 19 minutes 00 – (24 hour and 00 min.)

#### *4.3.1.4. Motivation and attitudes*

Non applicable

#### *4.3.2. Work related factors:*

##### *4.3.2.1. Tasks planning.*

• SE NRIC – railway infrastructure manager, carries out maintenance, repair and operation of the railway infrastructure. Annually prepares together with the railway undertakings a schedule for the train movement along the railway infrastructure of the Republic of Bulgaria. Prepares schedules and timetables on requests submitted by railway undertakings/carriers for movement of trains and vehicles on all railway lines

• „BDZ-Passenger Services“ EOOD – national railway undertaking, which performs passenger transport under approved Schedule of train movement and Train composition plan under the Contract for passenger service with the state.

##### *4.3.2.2. Constructive particularities of the facilities that influence the connection human-machine.*

Non applicable.

##### *4.3.2.3. Communication means.*

• The communication connections between Kaspitchan and Provadiya stations are carried out with "Disim Pab" equipment, when activating the level crossings, "Balkantel" equipment is used. "Nokia and Multiplex" equipment is used to provide a telecommunication connection between the operational staff at the Kaspitchan and Provadiya stations.

- In the locomotive cabins there are installed devices for analogue and digital communication with TDRC and GSM R to establish a connection between the locomotive driver and the traffic manager on duty at the respective station. The staff on shift at the stations of SE NRIC and the transport staff of BDZ PS EOOD are provided with official mobile phones.

#### *4.3.2.4. Practices and processes.*

Non applicable.

#### *4.3.2.5. Operation rules, local instructions, staff requirements, prescriptions for technical maintenance and applicable standards.*

- BDZ PS EOOD and SE NRIC apply national and departmental normative acts part of SMS referring the entities activity.

#### *4.3.2.6. Working time of the involved personnel.*

- The staff involved in the accident of both entities BDZ PS EOOD and SE NRIC works in shifts regime of 12-hour working shift. In accordance with the requirements of the normative acts - Labour Code and Ordinance № 50 of 28.12.2001 for the working hours of the managerial and executive staff, engaged in providing the transportation of passengers and freights in the railway transport.

#### *4.3.2.7. Risk treatment practices.*

- SE NRIC applies safety procedure SP 2.09 „Methods of evaluation, assessment and management of the risk „version 05 effective from 01.03.2019, which is part of the SMS. Register of hazards and their evaluation in the case of change of subsystems at SE NRIC;

- „BDZ-Passenger services“ EOOD applies the following procedures:

- Methods of the safety risk assessment at BDZ PS EOOD;
- Quality procedure QP-2-15 „Safety management of passenger services. Monitoring and information exchange“;
- Hazard register within operation, repair and maintenance of PTRRS within BDZ PS EOOD.

#### *4.3.2.8. Context, machinery, equipment and indications for shaping the working practices*

Non applicable.

### *4.3.3. Organizational factors and tasks:*

#### *4.3.3.1. Planning of the working force and the working load.*

In the entities BDZ PS EOOD and SE NRIC, in accordance with the requirements of national regulations, developed methodologies and shared good European practices, the work is planned and related in accordance with SMS to the personnel directly responsible for the safe operation of railway transport.

#### *4.3.3.2. Communications, information and teamwork.*

Non applicable.

#### *4.3.3.3. Recruitment, staffing requirements, resources.*

##### Railway undertaking:

- In BDZ PS EOOD, personnel selection is carried out according to an approved "Human Resources Management System", which includes:

- Rules for staff recruitment and selection;
- Rules for appointment and changes in employment relationships;
- Staff training and development rules;
- Rules for ensuring SHWC, Ecology, and organization of the activity of STM.

The entity's personnel is selected and appointed with the relevant legal capacity, professional qualification and skills for working in the management and executive staff.

##### Railway infrastructure:

- SE NRIC has an approved "Strategy for Human Resources Management 2021÷2025".

In the SE NRIC, the selection of personnel is carried out according to the established "Rules for recruitment, selection and appointment of personnel in the central administration of the SE NRIC" in force from 01.12.2020.

The recruitment, selection and appointment of personnel is carried out by the "Human Resources Management" department, which is responsible for:

- Recruitment;
- Maintaining a database of the personnel;
- Creation of a system of selection techniques for recruitment;
- Carrying out the selection together with the head of the unit;
- Documenting the process and communicating with staff;
- Appointment.

#### *4.3.3.4. Implementation management and supervision*

Non applicable

#### *4.3.3.5. Compensation (remuneration).*

##### Railway undertaking:

• BDZ PS EOOD has approved "Internal rules for wages" effective from 01.07.2013, which regulate the general conditions for the organization of wages:

- Formation and distribution of funds for salary in the company;
- Determination and amendment of the basic salaries by position;
- Determination of the types and amounts of additional and other remunerations;
- Regulation of the order and manner of payment of staff salaries.

##### Railway infrastructure:

• SE NRIC has approved "Internal rules for wages" in force from 01.09.2014, which regulate issues related to the wages of the company's personnel:

- General provisions for the organization of the salary in the entity;
- Determining and distributing the funds for wages - sources, order and way of forming the remuneration;
- Determination and amendment of wages and additional remuneration;
- Regulation, order and method of payment of wages.

#### *4.3.3.6. Leadership, powers related issues.*

Non applicable.

#### *4.3.3.7. Organizational culture.*

Non applicable.

#### *4.3.3.8. Legal issues (including the respective European and national rules and provisions)..*

Non applicable.

#### *4.3.3.9. Regulatory framework conditions and safety management system application.*

##### Railway undertaking

- Directive (EU) 2016/798 of the European Parliament and of the Council of 11 May 2016 on railway safety;
- Commission Delegated Regulation (EU) 2018/762 of 8 March 2018 establishing common safety methods on safety management system requirements pursuant to Directive (EU) 2016/798 of the European Parliament and of the Council and repealing Commission Regulations (EU) No 1158/2010 and (EU) No 1169/2010;
- COMMISSION IMPLEMENTING REGULATION (EU) 2019/779 of 16 May 2019 laying down detailed provisions on a system of certification of entities in charge of maintenance of vehicles pursuant to Directive (EU) 2016/798 of the European Parliament and of the Council and repealing Commission Regulation (EU) No 445/2011;



- COMMISSION IMPLEMENTING REGULATION (EU) No 402/2013 of 30 April 2013 on the common safety method for risk evaluation and assessment and repealing Regulation (EC) No 352/2009;
- Railway Transport Act;
- ORDINANCE No 59 dated 5.12.2006 on the railway transport safety management.

*Railway infrastructure:*

• Directive (EU) 2016/798 of the European Parliament and of the Council of 11 May 2016 on railway safety;

• Commission Delegated Regulation (EU) 2018/762 of 8 March 2018 establishing common safety methods on safety management system requirements pursuant to Directive (EU) 2016/798 of the European Parliament and of the Council and repealing Commission Regulations (EU) No 1158/2010 and (EU) No 1169/2010;

• COMMISSION IMPLEMENTING REGULATION (EU) 2019/779 of 16 May 2019 laying down detailed provisions on a system of certification of entities in charge of maintenance of vehicles pursuant to Directive (EU) 2016/798 of the European Parliament and of the Council and repealing Commission Regulation (EU) No 445/2011;

• COMMISSION IMPLEMENTING REGULATION (EU) No 402/2013 of 30 April 2013 on the common safety method for risk evaluation and assessment and repealing Regulation (EC) No 352/2009;

• Railway Transport Act;

• ORDINANCE No 59 dated 5.12.2006 on the railway transport safety management.

*4.3.4. Environmental factors:*

*4.3.4.1. Labour conditions (noise, illumination, vibrations).*

Non applicable for SE NRIC and BDZ PS EOOD.

*4.3.4.2. Meteorological and geographic conditions.*

• Kaspitchan station is located in the north-eastern part of the railway network;

• The accident occurred in the dark part of the day at 19:35 p.m.;

• Air temperature +12°C;

• Wind speed and direction around 0 m/s;

• Weather – clear, quiet with good horizontal visibility;

*4.3.4.3. Construction works, performed on the spot or in very proximity.*

In the area of the Kaspitchan station, as well as in the Kaspitchan - Provadiya interstation, no construction and repair works on the railway infrastructure (rail track and facilities, catenary and signalling equipment) were carried out by the manager of the railway infrastructure.

*4.4.5. Any other significant factor for the investigation objectives.*

Non applicable.

***4.4 Feedback and control mechanisms, including risk and safety management, as well as monitoring processes***

*4.4.1. Regulatory framework conditions.*

Commission Delegated Regulation (EU) 2018/761 of 16 February 2018 establishing common safety methods for supervision by national safety authorities after the issue of a single safety certificate or a safety authorisation pursuant to Directive (EU) 2016/798 of the European Parliament and of the Council and repealing Commission Regulation (EU) No 1077/2012

Commission Delegated Regulation (EU) 2018/762 of 8 March 2018 establishing common safety methods on safety management system requirements pursuant to Directive (EU) 2016/798 of the European Parliament and of the Council and repealing Commission Regulations (EU) No 1158/2010 and (EU) No 1169/2010

ORDINANCE No 59 dated 5.12.2006 on the railway transport safety management.

*4.4.2. Processes, methods and results from the activities on the risk assessment and monitoring that the involved entities performed:*

*4.4.2.1. Railway undertaking:*

- "BDZ-Passenger Services" EOOD implements the Quality Management System QP 2-15 "Safety Management of Passenger Services. Monitoring and exchange of information". In section 6.7. "SMS implementation control, item 6.7.2. "Periodic control of the implementation of the SMS is carried out through internal audits: monthly and complex (annual). Complex audits are conducted once a year on all the safety-related structures."

- In accordance with the requirements of the "Methodology for safety risk analysis and assessment in force from 23.02.2012", the railway entity BDZ PS EOOD prepares and presents monthly reports for the current year, as well as a complex (annual) audit report for the previous year regarding risk monitoring against the Investigation Commission at the NAMRATIB.

*4.4.2.2. Railway Infrastructure:*

- SE NRIC applies Safety Procedure SP 2.09 "Methodology for identification, assessment and risk management" version 05 in force from 01.03.2019 which is part of the SMS.

*4.4.2.3. Entities in charge of the technical maintenance.*

*Railway undertaking*

- "BDZ-Passenger Services" EOOD owns the Certificate of an entity in charge of maintenance No BG /31/0021/ 0001, valid from 19.04.2021 to 18.04.2026;

*Railway infrastructure:*

- SE NRIC has a Certificate of an entity in charge of maintenance with UIN BG /31/0020/ 0003, valid from 01/07/2020 to 30/06/2025.

- SE NRIC has a Certificate of an entity in charge of maintenance of railway vehicles with UIN BGRA 2020/0004, valid from 01/07/2020 to 16/06/2023.

*4.4.2.4. Producers and all other participants.*

Non applicable.

*4.4.2.5. Reports for independent risk assessment.*

No assessment has been made by an Independent Assessor (AsBo) of any changes in operating conditions or factors relevant to the occurred accident.

*4.4.3. Safety management system of the involved:*

*4.4.3.1. Railway undertaking.*

"BDZ-Passenger Services" EOOD implements "Methodology for Analysis and Assessment of Risk Safety ", which is part of the SMS. Register of hazards in the operation, repair and maintenance of RRS in BDZ PS EOOD, which changes when changes occur.

*4.4.3.2. Railway infrastructure.*

SE NRIC implements a safety procedure SP 2.09 "Methodology for determining, assessing and managing the risk" version 05 effective from 01.03.2019, which is part of the SMS.

*4.4.4. Safety Management System of the entities in charge of the technical maintenance.*

"BDZ-Passenger Services" EOOD implements an approved "Safety Management System" effective from 30.07.2017, which also regulates the technical maintenance of traction and non-traction rolling stock.

SE NRIC implements Safety Procedure SP 7.01 "Regulations for maintaining the signalling system (Signalling equipment)", which is part of the SMS;

SE NRIC implements approved "Rules for current maintenance of the rail track" effective from 2021.

#### *4.4.5. Results from the supervision, performed by the National Safety Authority.*

The results of the performed audits and inspections regarding the functioning of the Safety Management System of SE NRIC and "BDZ-Passenger Services" EOOD in accordance with the requirements of Regulation (EU) 2018/761, Regulation (EU) No. 1169/2010, Ordinance No. 56 and Ordinance No. 59 for respecting the specific requirements of European legislation and national rules for the design, maintenance and operation of the managed railway infrastructure, show that the companies maintain the SMS and can fulfil the requirements provided for in the relevant legal acts.

In the period from 19.10.2020 to 30.10.2020, the National Safety Authority (NSA) carried out an annual planned supervision of the SMS of SE NRIC.

In the period from 08.02.2021 to 19.02.2021, the National Safety Authority (NSA) carried out an annual planned supervision of the SMS of "BDZ-Passenger Services" EOOD.

#### *4.4.6. Permits, certificates and assessment reports, provided by the National Safety Authority or other Conformity Assessment Bodies:*

##### *4.4.6.1. Safety certificates of the involved railway infrastructure managers.*

Safety Authorization No BG 21/2018/0001 valid from 01.07.2018 to 30.06.2023.

##### *4.4.6.2. Safety certificates of the involved railway undertakings.*

"BDZ-Passenger Services" EOOD owns a Single Safety Certificate with EU ID number BG 10 2022 0298, valid from 31/12/2022 to 30/12/2027;

##### *4.4.6.3. Authorizations for placing in service of permanently fixed equipment and permits for placing on the market of vehicles.*

Non applicable.

##### *4.4.7. Other system factors.*

Non applicable.

#### **4.5. Previous similar cases.**

- A fire broke out in a coach of passenger train No. 50215 during a stay at the Pernik marshalling yard on 04/09/2021. Train No. 50215 departed according to schedule from the Sofia station at 22:30 p.m. with the route Sofia - Vladaya - Pernik marshalling yard - Pernik. The train was serviced by electric locomotive No. 91520044098-9 with a first-person locomotive driver and a second-person locomotive driver and a transport crew train master and conductor. The train was operated by a railway company for passenger transport "BDZ-Passenger Services" EOOD.

At the Pernik marshalling yard, the train arrived at 23:18 p.m. on the fourth main track and, after a one-minute delay, departed at 23:19 p.m. When the train started, an emergency brake was applied from the fifth coach by an unknown person (passenger) and the train stopped. The traffic manager on duty noticed that smoke was coming from the last fifth coach No. 51522563019-0 of the train. He took a fire extinguisher from the station and went to the burning coach. Upon opening the door of the coach, he noticed that thick black smoke and flames were coming from the inside of the coach that stopped him from entering. The passengers of the train were evacuated to a safe distance by the train master and the conductor, and the coach was separated from the train. At 23:40 p.m., a specialized vehicle of FSaCP - Pernik arrived and the fire in the coach was extinguished at 00:20 a.m. No passengers or staff were injured in the fire.

The most probable cause of the accident was forced ignition from an external source in the area of the loudspeaker and matching transformer of the sound system, located in the passenger baggage area above the seats in the coach.

- A fire broke out in a passenger coach of high-speed train No. 8613 during a stay at Konyovo station on 30.03.2018. On 30.03.2018, high-speed train No. 8613, consisting of 4 cars, 16 axles, departed from Sofia station to Burgas station, 164 tons, serviced by electric locomotive No. 91520043309-4. The route of the train is Sofia – Plovdiv – Dimitrovgrad – Stara Zagora – Burgas. The staff on duty at the stations along the route did not notice anything unusual when the train passed. The same was confirmed

by the locomotive and transport crews that serviced the train from Sofia station until its arrival at Konyovo station.

The train arrived at Konyovo station at 19:59 p.m.. According to "Plan II-24", the train was accepted on the second acceptance-departure track and according to the schedule it was supposed to stay for 5 minutes to meet the express train No. 8632 passing through the station. After the stop of express train No. 8613 at the station, the traffic manager on duty saw smoke coming out between the 3rd and 4th carriages. Soon after, a large fire developed at the end of the 3rd car, which subsequently engulfed the 4th car and burned. For the situation that arose at Konyovo station, the train dispatcher ordered the traffic manager on duty at Kermen station to hold fast train No. 8632 at the station. The passengers of the train were evacuated to a safe distance by the train master and the conductor. No passengers or staff were injured in the fire.

The cause of the fire in the 3rd carriage was a short circuit accompanied by a voltage arc between the plus wires feeding the 220 V Inverter, which was in contact with its body shell. The positive and negative wires for the 24V power supply of the Inverter are mechanically frayed due to the Inverter being disconnected from the electrical panel and hanging on the cables, which has caused thermal stress on the insulation. The reduced dielectric strength and the occurrence of leakages between the negative wire and the inverter housing and between the positive wire and the inverter housing resulted in a short circuit that caused the fire in the coach.

## **5. Conclusions**

### ***5.1. Summary of the analysis for the event causes.***

The safety investigation commission at the NAMRATIB carried out several inspections of the two burned coaches No. 50522974242-2 type B4, No. 50521974003-0 type A4 in the Gorna Oryahovitsa wagon depot, got acquainted with the provided documentation on the technical condition of the wagons and the types of repairs carried out up to the time of the fire provided by the railway undertaking BDZ PS EOOD. The railway company did not provide the Investigation Commission with the documentation regarding the overhaul of the first-class coach No. 50521974003-0 in 2007 at "Kolowag" AD, Septemvri. For this reason, the Commission was not able to document the technical condition of the coach after the overhaul.

During the first medium repair carried out at the Dryanovo Wagon Plant in 2013 and the second medium repair at the Nadezhda Wagon Depot in 2020, no changes were found in the electrical equipment of the coach that could be related to the ignition that occurred.

The Investigation Commission found that the high-voltage power supply cabinets of the coach, located under the frame of the coach and intended to provide primary power to the electrical system of the coach, were technically sound. It was established that the batteries providing power in the absence of external voltage were in good working condition and were not affected by the fire. It was also found that the apparatus cabinet, which housed the apparatus for powering the electrical system of the coach, was in working condition and was not affected by the fire. The conclusion followed that the part of the electrical equipment of the coach was not the cause and had no connection with the fire that occurred.

From the analysis of the power inverter unit of the lighting fixtures in the area of the entrance space and the toilet unit of the coach, the following conclusions can be drawn:

As a result of accumulated systematic mistakes when repairing the lighting fixtures and installing unsuitable elements in them, the temperature in the power supply unit rose unacceptably, which led to the melting and ignition of the elements and their insulation in the inverter, which caused the fire.

No other malfunctions were found on the coaches and locomotives of FT No. 2613, referring the occurrence of the accident.

### ***5.2. Undertaken measures after the event occurrence.***

The Railway Infrastructure Manager has undertaken to restore the schedule and capacity of the railway infrastructure, by inspecting and repairing the catenary damage that occurred as a result of the fire. Inspections of the rail track and signalling equipment, unaffected by the fire, were carried out.

Traffic on track No. 2 was restored on 04.11.2022 at 00:57 a.m. according to schedule.

At 13:55 p.m. with diesel locomotive No. 985200550947, the composition of FT No. 2613 (locomotive and coaches) was withdrawn from the interstation at Kaspitchan station.

To restore the integrity of the catenary in the Kaspitchan - Provadiya interstation, track No. 1 at 14:13 p.m. from Kaspitchan station, RSPM No. 995294360277 was sent, which, after removing the damage to the catenary, returned at 16:03 p.m.

The movement of trains on track No. 1 was restored on 04.11.2022 at 16:14 p.m.

On 04.11.2022 at 15:30 p.m., after a technical inspection of the two burned coaches from FT No. 2613 (a total of four passenger coaches) with a prescribed speed of up to 60 km/h, it was moved from Kaspitchan station to Wagon- repair depot Gorna Oryahovitsa.

### ***5.3. Additional findings.***

There are no prescribed procedures regulating the actions of the personnel directly related to switching off and switching on the voltage in the catenary (train, energy dispatcher and locomotive driver) in the event of accidents (including a fire in the rolling stock) during the movement of the train. That caused the fire to spread from the second to the first coach of the train, and subsequently created a danger of catching fire and burning the train locomotive. Timely intervention of the locomotive crew together with passengers from the train prevented the locomotive from catching fire, who uncoupled it from the burning coaches and moved it to a safe distance.



## 6. Safety recommendations

In order to improve the safety in the rail transport, the Investigation Commission at NAMRATIB proposes to the Railway Administration Executive Agency (RAEA) the following safety recommendations adapted to SE NRIC and "BDZ-Passenger Services" EOOD.

- Recommendation 1, proposes that SE NRIC and "BDZ-Passenger Services" EOOD familiarize the interested personnel with the contents of the report.

- Recommendation 2, proposes that BDZ PS EOOD organizes the performance of monthly discussions and gets acquainted the operation and repair personnel in the wagon-repair depots of the entity with the circumstances and causes for the accident occurrence.

- Recommendation 3, proposes BDZ PS EOOD, when carrying out major repairs of passenger coaches in railway depot, to control the requirements for compliance with the relevant fire protection requirements for electrical installations and internal equipment, listed in Regulation (EU) No. 1302/2014 of the Commission of November 18, 2014.

- Recommendation 4 proposes BDZ PS EOOD during the monthly electrical revisions of the passenger coaches, series 1974 and 2974 to undertake inspection and measurements of the electrical installations and equipment in order to prevent ignition of other coaches. To install video surveillance cameras in the passenger coaches.

- Recommendation 5, proposes that the Railway Administration Executive Agency undertakes an amendment and supplement to the legislation regulating the actions of the operating personnel related to switching off and switching on the voltage in the catenary in emergency cases where a fire has occurred in the rolling stock (locomotive or wagons) during the train movement along interstation.

With reference to the requirements of art. 24, paragraph 2 of Directive (EU) 2016/798, and art. 91, paragraph 3 of Ordinance No 59 dated 5.12.2006, the member of the Management Board of NAMRATIB on 15.06.2023 provides a final report that contains information on the investigation of the accident with formulated and agreed safety recommendations in order to improve safety in railway transport.

In accordance with Art. 26, paragraph 3 of Directive (EU) 798/2016, that the National Safety Authority (RAEA) and other bodies or structures to which the safety recommendations are addressed, to report regularly to the member of the management board of the NAMRATIB on the measures taken or planned as a result (sequence) from the recommendations.

### Chairperson:

**Dr. Eng. Boycho Skrobanski**

*Deputy President of the NAMRTAIB AB*

### Members:.....

1. ....(s)..... **(External expert)**
2. ....(s)..... **(External expert)**
3. ....(s)..... **(External expert)**

*I, the undersigned Giulietta Marinova Marinova-Popova, certify that this is a true and accurate translation done by me from Bulgarian into English of the attached document.*

*The translation consists of 51 pages*

*Translator: Giulietta Marinova-Popova*